

# INDUSTRIAL PROFILE SYSTEMS



Industrial Equipment



Machine cabins



Study desks



Security Systems

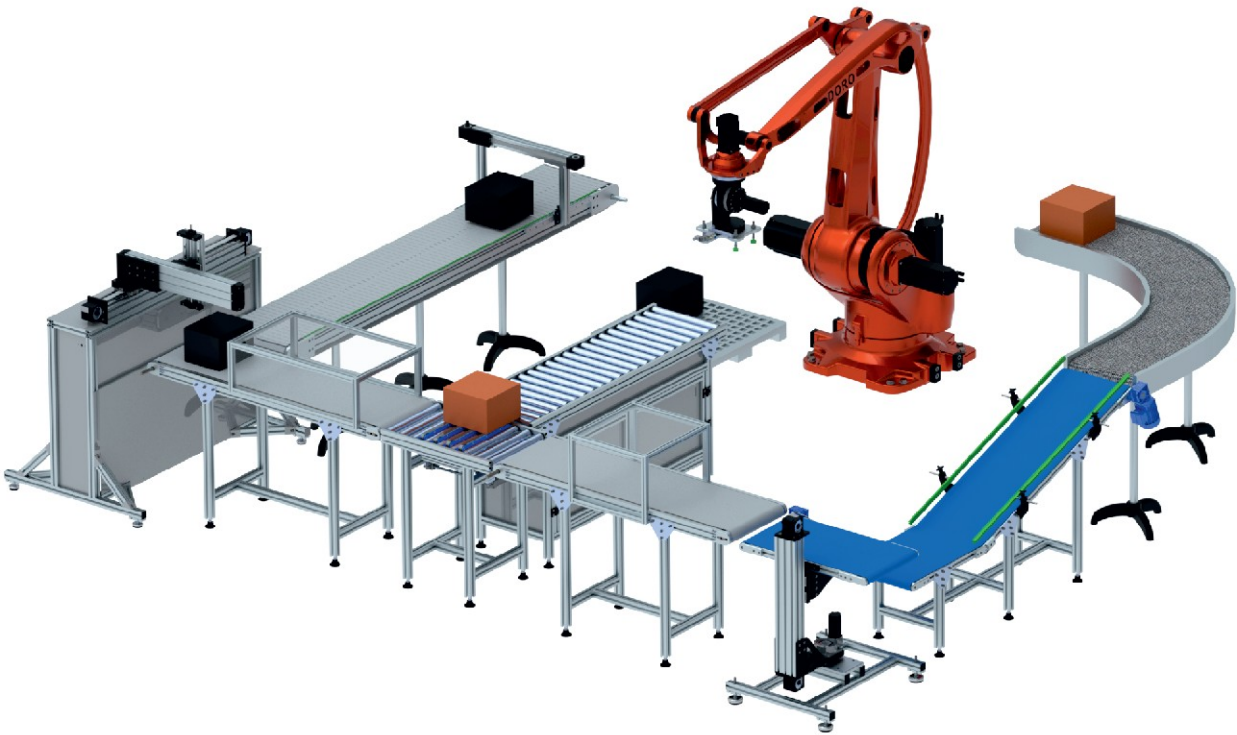

## MODULAR CONSTRUCTION TECHNOLOGIES

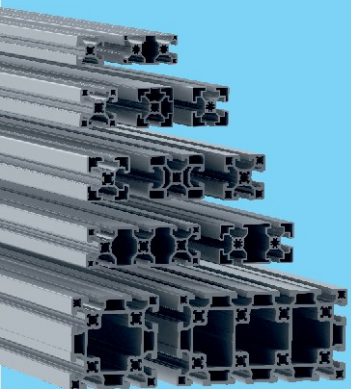

**PRODUCT CATALOGUE**

[www.doguskalip.com.tr](http://www.doguskalip.com.tr)



*Let's shape life together...*

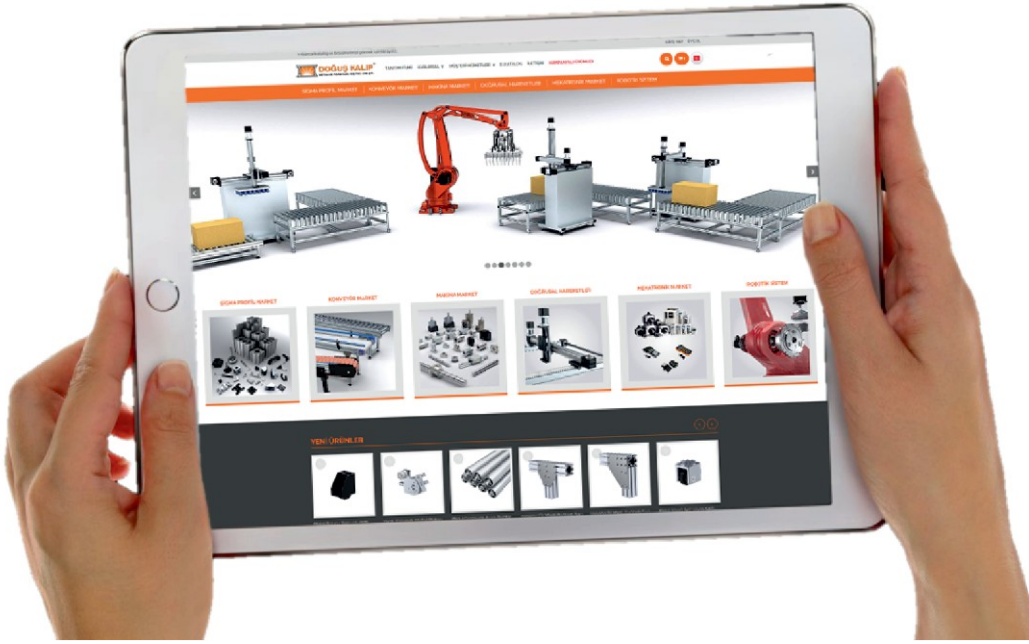

*Our Online Sales Site is Open to Service.*

[www.doguskalip.com.tr](http://www.doguskalip.com.tr)

These Products Are Each **Doğuş Kalıp** Brand.



**MECHATRONICS MARKET®**



**ROBOTIC MARKET®**

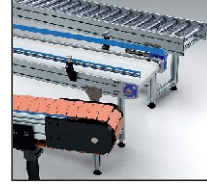

**CONVEYOR MARKET®**



**SIGMA PROFILE MARKET®**



**MACHINE MARKET®**

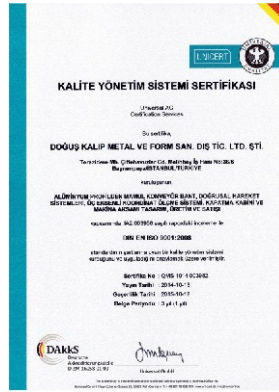



## Company Profile

*Doğuş Kalıp Metal ve Form San. Tic. A.Ş. which started business in 1994 and made name by manufacturing cutting and plastering mould, progressive mould for different sectors, has improved its experience by carrying out activities in production and spare part manufacturing since 1998.*

*Doğuş Kalıp has started producing Aluminium Industrial Profiles, fastening-connecting parts and their accessories on conveying and automation systems after 2002.*

*It has contributed to national labour force by manufacturing the equipments which were imported products.*

*Since 2006, Dogus Kalip has focused on research and development on linear motion systems and multi-axis motion systems and produced world-ranking technological systems by using its own resources.*

*Today, there is a great competition in both quality and speed by using cutting-edge technological systems and newly developed products in production process and manufacturing industries .*

*Doğuş Kalıp is a manufacturer of the products which used in serial manufacturing of mechatronics and automation technology applications. We are proud with our research and development department facilities on developing the necessary products in mechatronic sector.*

*Our main target is improving the systems and equipments in necessity of our sector with our expanding quantity of staff and background.*

*We have partnership with lots of manufacturer in mechatronics and automation sector due to our product range expanding day by day.*

*Our marketing strategy is almost completed in domestic market with Dogus Kalip's regional and local dealers and Doğuş Kalıp is to be continue to trading with foreign countries.*

*We know our responsibility to giving best service and high quality to our customer and partners. We wish to share our experience and develop your business in close future.....*

Strong  
Stock

High  
Quality

Engineering  
Service



Innovation

Fast  
Service

CRM

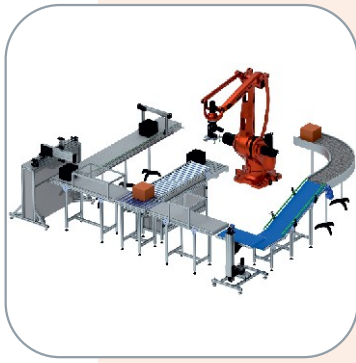

## Applications



## Industrial Aluminium Profiles

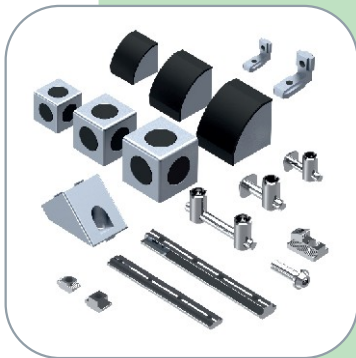

## Connection Equipments



## Connection Accessories



## Safety Equipments

Surface Covering Options  
Chassis Applications  
Production Lines

Machine Applications  
Cabin Applications  
Study Desks

Stands and Panels  
Conveyor Applications

Page

7-17

Profile values	40x40 SL K10	45x90 A	90x90SL	45x45R	25x150 Cone Prof.
20x20	40x40 L K10	40x120	90x90L	80x80R	45x75 Cone Prof.
25x25	40x40 A K10	45x135	90x90A	30x30K	Ø50 Tamb. Prof.
20x40	40x80 SL K8	45x180	100x100L	40x40K	Ø50x1.5 Pipe Prf.
20x80	40x80 L K8	50x50 A	90x180L	45x45K	Ø76 Ø114 Tamb. Prof.
30x30SL	40x80 A K8	50x100 A	90x180A	30x60K	Ø12 - Ø20 Block Bearing Prf.
30x30L	40x80 SL K10	60x60	90x135A	40x80K	38x50 Bearing Prof.
30x30A	40x80 L K10	60x60 Ç	135x135A	45x90K	60x80 Bearing Prof.
30x60 SL K8	40x80A K10	60x90 A	10x40 Surface cap. Prof.	22x140 Surface cap. Prof.	80x80 Bearing Prof.
30x60	45x45 USL	60x120 L	22.5x45 Panel Prof.	27x170 Surface cap. Prof.	Ø12 - Ø20 Bearing Nail Prf.
30x90	45x45 SL	80x80 L K10	30x45 Graded	15x120 Surface cap. Prof.	Shaft Lower Support Connect. Plate
35x35L	45x45 L	80x80 A K8	40x40x45° Sigma	22.5x180 Surface cap. Prof.	Lower Support Profile
35x35A	45x45 A	80x80 A K10	Stand of 30 Prof.	23x75 Kon Prof.	Shaft Lower Support Prof. + Miles
40x40 SL K8	45x90 SL	80x120 A K10	20x20R	23x127 Kon Prof.	18x28 K8 Slider
40x40L K8	45x60	80x160 L K8	30x30R	25x105 Cone Prof.	18x37 K10 Slider
40x40 A K8	45x90 L				

18-58

Straight Corner Connections  
Angled Corner Connections  
Narrow Snap Corner Connection and Cap.  
Long Corner Connection and Cap.  
Wide Corner Connection and Cap.  
Square Corner Connection and Cap.  
Three Way Corner Connection and Cap.  
45° Fitting  
Radius Corner Connections and Caps.  
Butt Bolts

In-Channel Connection  
Hidden Corner Connections  
Movable Joints  
Angled Puller Type Connection  
Articulated Puller Type Connection  
Straight Pull Type Connection  
Butt Pull Type Connection  
Stud Nuts  
Knurled Nuts

Spring Channel Nuts  
Module T Channel Nuts  
Long T - T Channel Nuts  
Rectangular and Square Nuts  
Shelf Adjusting Sheet  
Parallel Joint  
90° Fittings  
120°-135° Connection Parts  
Connection Plates

59-82

Magnet Connection Kit  
Foot Ground Connection Piece  
Foot Fixing Piece  
Corner foot connection plate  
Wheeled Foot Connection Plate  
Wheels with Brakes  
Plastic and Metal Feet  
Profile Corner Covers  
Profile Covers  
Profile Protector Rubber 45x45 Three Surfaces  
Profile Protector Rubber K10 Single Surface  
Sheet Wick  
Sheet Compression Roving

Channel and Glass Wicks  
Locking Hinges  
Covered Hinge  
hinges  
Plastic Handle  
Ball Snap  
Security Lock  
Ball Lock  
Shock Absorber and Link Part  
Hole Drilling Tools  
plexiglass  
Solid Polycarbonate  
Corrugated Polycarbonate

Plexiglass Holder (With Tabs)  
Plexiglass Holder (With Nut)  
Plexiglass Holder Metal (Single)  
Plexiglass Holder Metal (Double)  
Cable Holder (Without Cover)  
Cable Holder (With Cover)  
Slide Rails  
Slide Pins  
Hanger Apparatus  
Switchblade Arm

83-108

Channel Slider Set  
Channel Slide Wheel  
In-Channel U Wick  
Security Panels

Çalışma Masaları  
Taşıma Araçları  
Study Desks  
Transport Trolleys  
Tool Stands  
Roller Railbaları  
Avadanlık Standları  
Makaralı Ray

109-115

### WHAT IS THE INDUSTRIAL ALUMINIUM PROFILE?

**Industrial Aluminium Profile** is a kind of technical product which is used as alternative of steel constructions. These profiles specially designed for mechanical application ranges which is possible for using on building strong constructions against the static and dynamic loads with their 6 mm, 8 mm ,10 mm slot dimensions.

Our profiles produced of special aluminium which is also called 6063 series. Also their surface is coated by eloxal that keeps the profile stronger against the corrosion . There is no need stoning and painting like on steel constructions with this features.

The most important factors; to prefer sigma profiles are serial assembly feature, strength, multifunction, ease to use and design features.

For suitable aluminum profile, it is easier and faster to assembly according to the special designed connection elements. They have minimum production planning time and material waste that's because it has modular structure, they are always suitable each other and they have very practical usage.

It's possible to make changes on constructions. All parts can be easily assembled additionally. **Doğuş Kalıp** presents standard profiles and their connection technics with many kind of design.

From these alternatives; **Aluminium Industrial Profiles** are suitable for any kind of usage besides it's the most preferred and low cost substructure product nowadays.



Sheet metal, chipboard, plexiglass, etc. used to cover the outer walls of all kinds of applications. alternative surface like It is possible to use coating options.

Composite Application

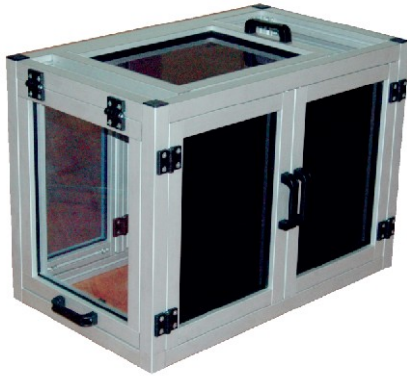

PVC Application



Perforated Sheet Application



Chipboard Application



Galvanized Sheet Closure



MDF Application



Surface Coating Options

Alternative options such as metal plate, laminated clipboard, plexiglass etc are available to cover all kind of applications.

Sigma profile, cross-sections selected according to the amount of weight and force required in the chassis and bodies of different designs and the desired construction is created with the help of standard fasteners. Below are some sample images There are.

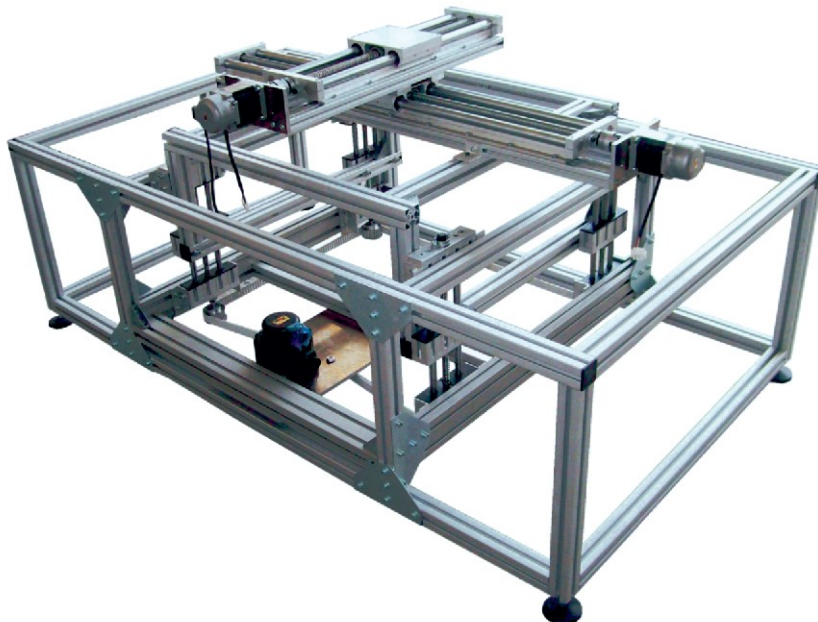
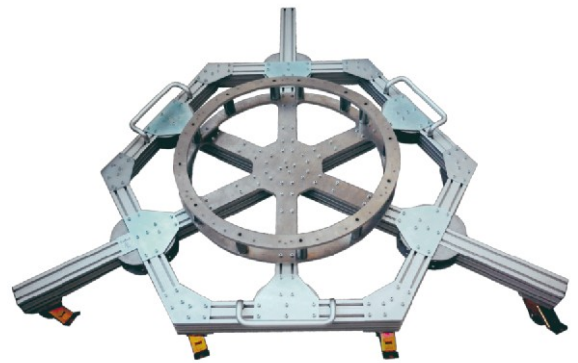

Desired constructions are formed by the aid of standard connectors and profile sections chosen according to momentum needed on chassis and frames.

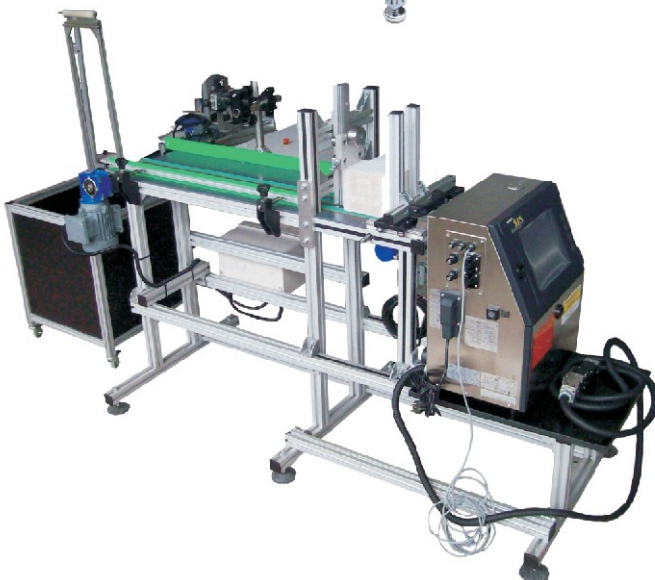
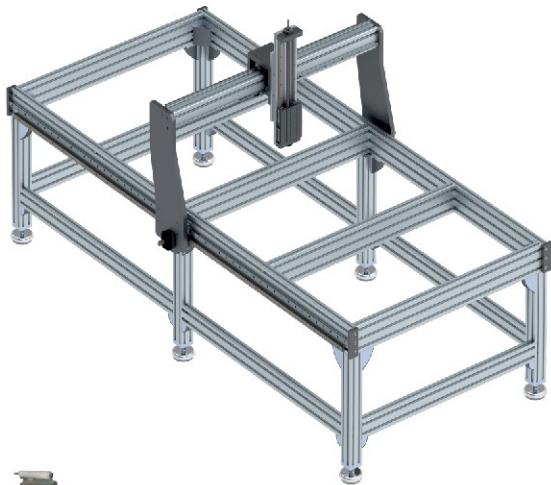

The use of sigma profiles in machine manufacturing is practical. At desired strength with variable connection options constitutes a structure. These features replace steel construction in many machine chassis. Cost Its use is preferred because it provides time and advantage.

Mobile Phone Assembly Line



Signal Lamps Assembly Line



Industrial aluminium profile provides ease in the machine manufacturing. It constutes of desired strenght with the variable connection type. These features take place of steel construction at the a lot of machine chassis. It is preferred firstly thanks to cost and time advantage.

Styrofoam Cutting Machine

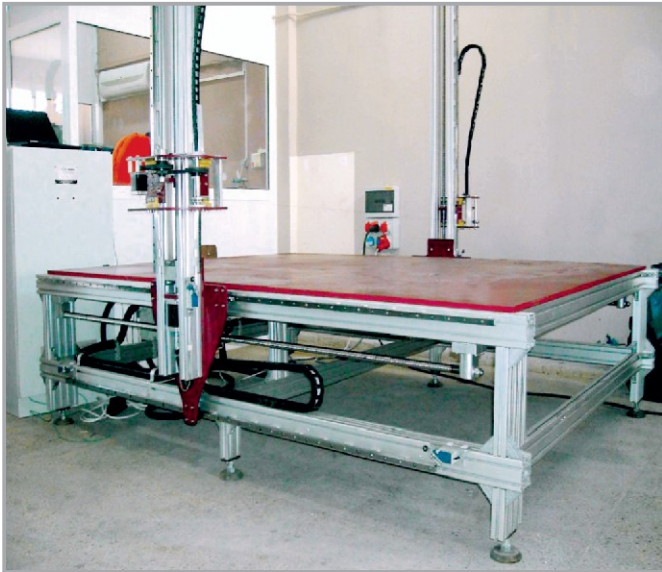

Packaging Machine



Laser Tester

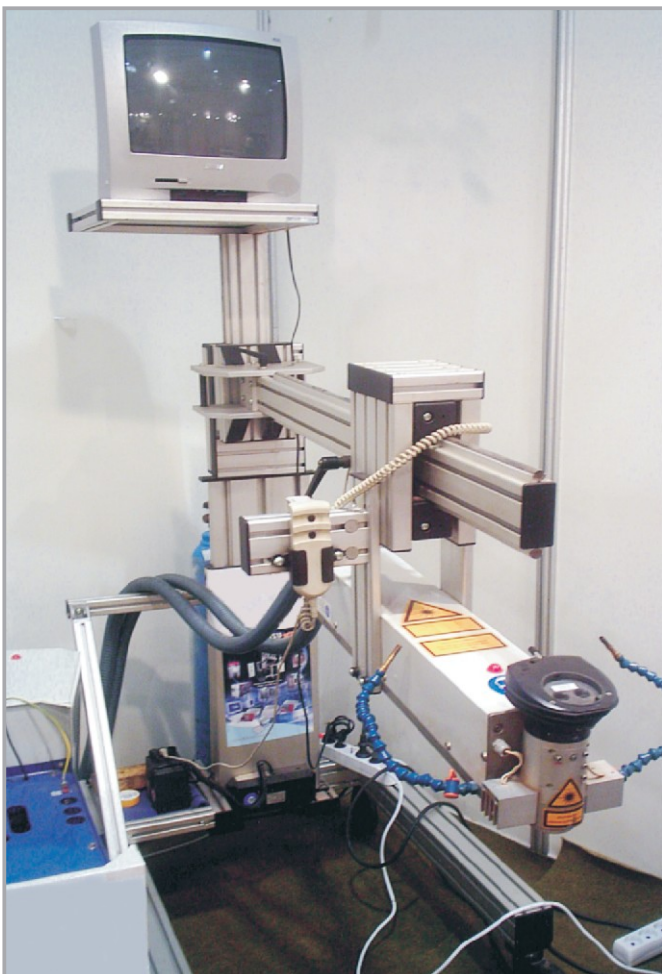

Pallet Feeding Machine



Sigma profiles are an ideal infrastructure material in all kinds of machine cabin construction. Plexiglasses of different colors are available. An aesthetic appearance is provided. Cabin cover options are designed to provide convenience at the place of use.

**Pneumatic System Protection Cabinet**

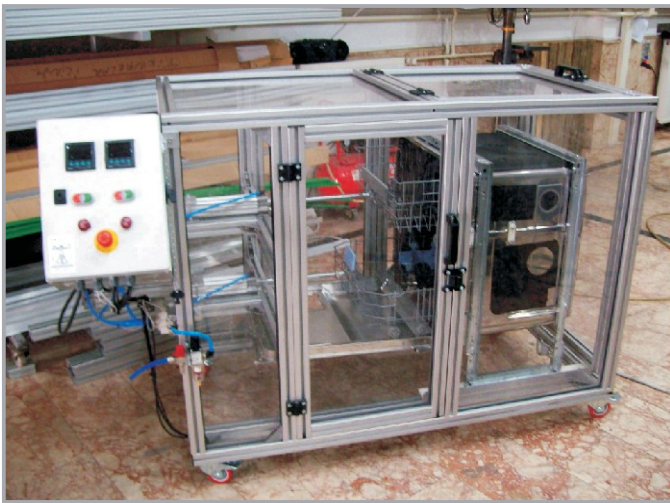

**Electronic System Protection Cabinet**



*Reasons for Preferring Machine Cabins: 1- Sound Insulation 2- Security 3- Hygiene 4- Aesthetics*

**Filling and Packaging Machine Cabinet**



**Flock Printing Machine Cabin**



**Laser Pattern Machine Cabinet**



Sigma profiles are an ideal material structure for making cabinet of all kinds of construction machinery. An aesthetics image is provided in different colors of plexsglass. Cabin cover options designed to provide simple usage into the place.

Pneumatic System Protection Cabinet



Press Printing Protection Cabinet



Sound Isolating Cabinet



Security Cabin



Bag Production Machine Cabin



Injection Security Fence

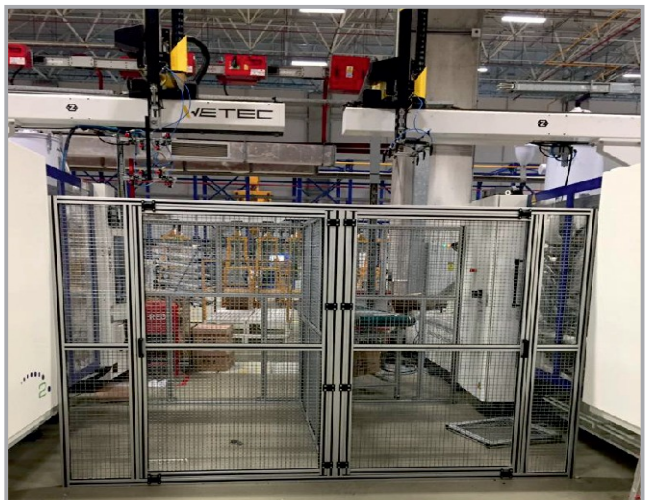

Work tables, which can be produced in variable sizes and designs, are mostly used in assembly and testing operations. is preferred. Units created with surface coated options provide aesthetic use.

Test Training Desk



Product Assembly Table



Product Assembly Teable



Study Desk



Product Assembly Table



Electronic Assembly Line



Work Tables

Working tables that is producible in variable dimensions is preferred for mounting and testing operations. It provides facility of working with PC, pneumatic, hand drill, clamp by the variety of surface coating.



Sigma Profiles are used in visual and decorative applications as well as in industrial areas. Also fair stands, panels, showcases etc. It can be used in areas.



Lighting Poles



exhibition stand



Promotion Board



Product Display Table



Product Shelf



Glass Stand



4x6 mt Double Storey Fair stand



Product Display stand

*Stand-Panel*

As industrial aluminium profile used on industrial applications, It is also used visual and decorative applications. Also it can be used on display constructions fair stand, clipboard applications.

Quick project manufacturing is possible thanks to profiles specially designed for all types of conveyors. Wanted Conveyors can be manufactured according to dimensions. You can find detailed parts information about conveyors on the conveyor materials page you can see.

Garlic Peeling Line



Product Transfer Line



Labeling Conveyor



Graded Delivery Conveyor



Graded Delivery Conveyor



Quick manufacturing can be done with profiles which are special designed for any type of conveyors. Conveyors are manufactured by desired size. You can see the detailed parts information about conveyors in conveyor equipment page.

360° Rotation Conveyor



Wire Belt Conveyor



(L) Type Elevator



Logistics Conveyor Line



Double Deck Conveyor



(Z) Type Elevator



**Formulas to be used in deflection calculation is as follows;**

- f (mm): Deflection
- F (N): Force
- L (mm): Profile length
- I (cm4): Moment of Inertia
- E (N/mm2): Elasticity Modulus

**Steps to follow when using the table:**

- The symbol F indicates the loading type in (N).
- Profile length (L) is stated in mm.
- As a first step, select the information that your profile will be exposed to in the left vertical column.
- Select the force (10N=1Kg)
- As seen in the table, select the profile length from the top horizontal row and match it.
- Select the moment of inertia of your profile from the right vertical column
- Length-force, provided that it remains between vertical inclined lines
- Align the point with the moment of inertia of the profile you selected.
- Using the last point you found as a reference, draw a vertical line downwards to create the profiles.
- Read the deflection amount according to suitable bearing positions from the chart.

You can practically calculate the deflection from the table by using our website;

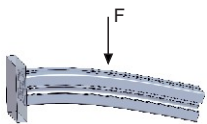

$$f = \frac{F.L^3}{3E.I.10^4}$$

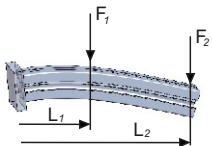

$$f = \frac{F_1.L^3 + F_1.L_1^2.L + F_2.L^3 + F_2.L_2^2.L}{3E.I.10^4}$$

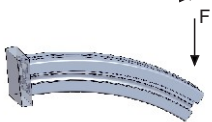

$$f = \frac{F.L^3}{8E.I.10^4}$$

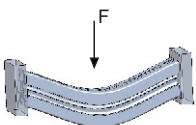

$$f = \frac{F.L^3}{48E.I.10^4}$$

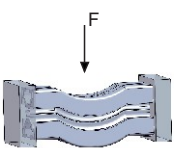

$$f = \frac{F.L^3}{192E.I.10^4}$$

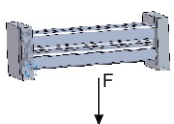

$$f = \frac{F.L^3}{384E.I.10^4}$$

Example

F=2000N

Profile length L=1000mm

with the point where F and L values coincide

the moment of inertia of your profile as follows:

Assemble as is, you found

from the reference point to the bottom of the diagram

correct upright lowering and proper bedding

Read the deflection value according to the shape.

According to these values

f:9.5mm in loading type

f:0.6mm in loading type

In loading type f: 015mm

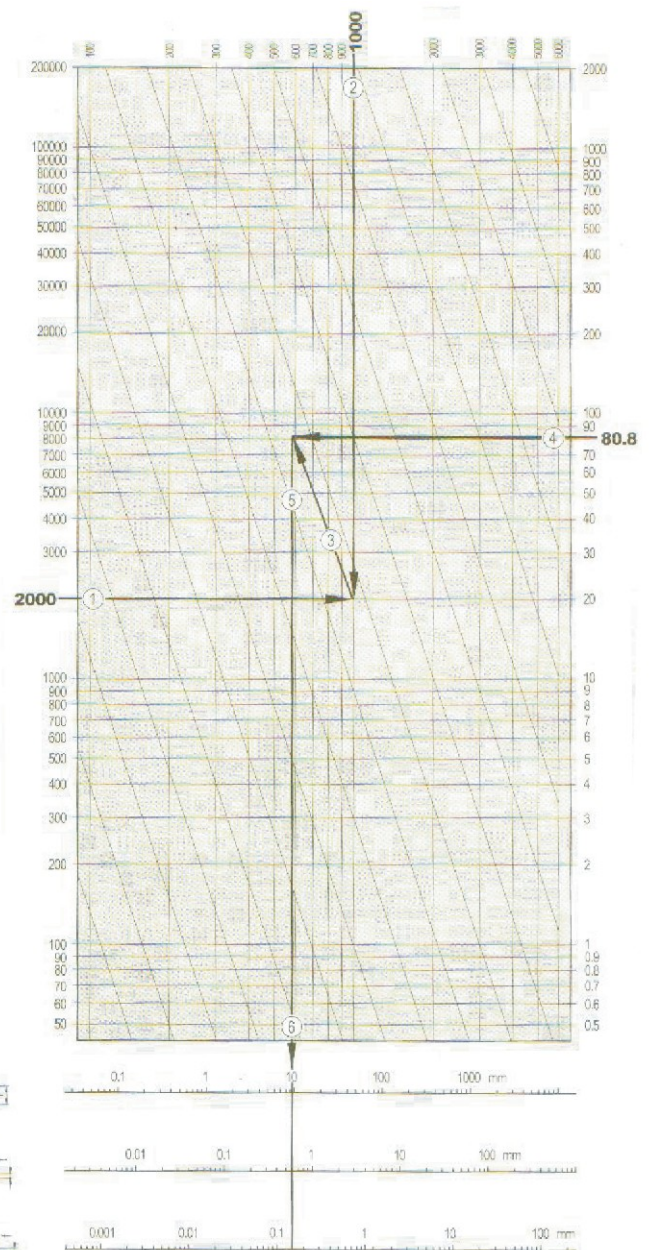

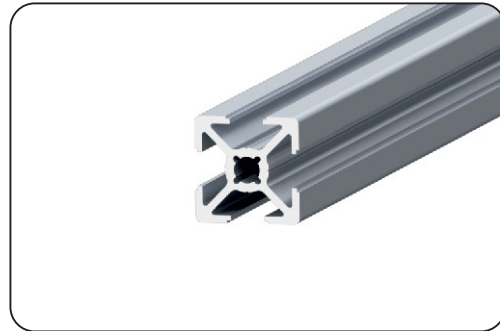
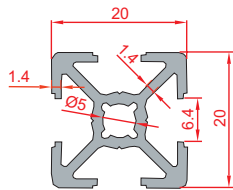
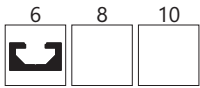

**20x20 Industrial Profile**

Code:1.1.06.020020.01

A profile preferred in optimizations of constructions such as small board, signboard, showcase etc.

Stock Code	External Dimensions	Material	Moment of Inertia		Moments of Stength		Area	Mass
			$I_x$	$I_y$	$W_x$	$W_y$		
1.1.06.020020.01	20x20	6063	$0.60\text{cm}^4$	$0.60\text{cm}^4$	$0.60\text{cm}^3$	$0.60\text{cm}^3$	$1.41\text{cm}^2$	0.38 Kg/m

Standard : 6010 mm Lmax : 7200 mm

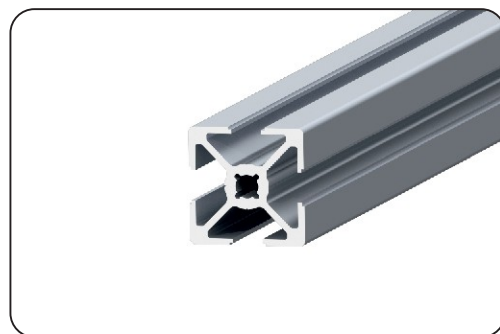
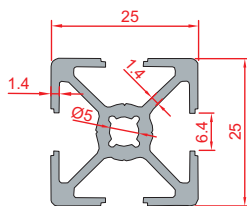

**25x25 Industrial Profile**

Code:1.1.06.025025.01

Preferred use in applications that do not require loading, such as cabin doors, frameworks and boards.

Stock Code	External Dimensions	Material	Moment of Inertia		Moments of Stength		Area	Mass
			$I_x$	$I_y$	$W_x$	$W_y$		
1.1.06.025025.01	25x25	6063	$1.39\text{cm}^4$	$1.39\text{cm}^4$	$1.11\text{cm}^3$	$1.11\text{cm}^3$	$2.12\text{cm}^2$	0.57 Kg/m

Standard : 6010 mm Lmax : 7200 mm

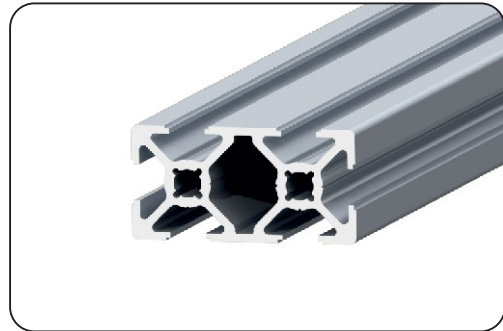
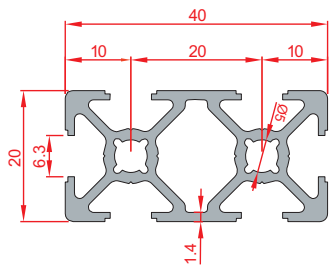
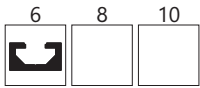

**20x40 Industrial Profile**  
Code:1.1.06.020040.01

Used in board applications of cabins that do not require loading, as in body formation of smaller frame constructions.

Stock Code	External Dimensions	Material	Moment of Inertia		Moments of Stength		Area	Mass
			$I_x$	$I_y$	$W_x$	$W_y$		
1.1.06.020040.01	20x40	6063	1.13cm <sup>4</sup>	4.17cm <sup>4</sup>	1.13cm <sup>3</sup>	2.09cm <sup>3</sup>	2.61cm <sup>2</sup>	0.71 Kg/m

Standard : 6010 mm Lmax : 7200 mm

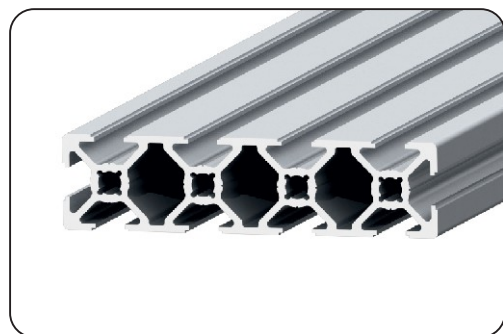
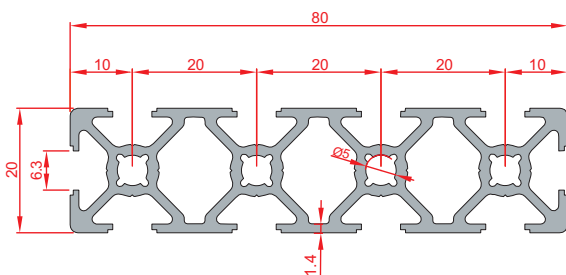
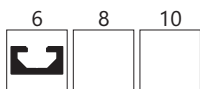

**20x80 Industrial Profile**  
Code:1.1.06.020080.01

Suitable for use in applications such as front board of work benches, compartment boards, light construction upper floor etc.

Stock Code	External Dimensions	Material	Moment of Inertia		Moments of Stength		Area	Mass
			$I_x$	$I_y$	$W_x$	$W_y$		
1.1.06.020080.01	20x80	6063	2.13cm <sup>4</sup>	29.29cm <sup>4</sup>	2.13cm <sup>3</sup>	7.32cm <sup>3</sup>	4.91cm <sup>2</sup>	1.33 Kg/m

Standard : 6010 mm Lmax : 7200 mm

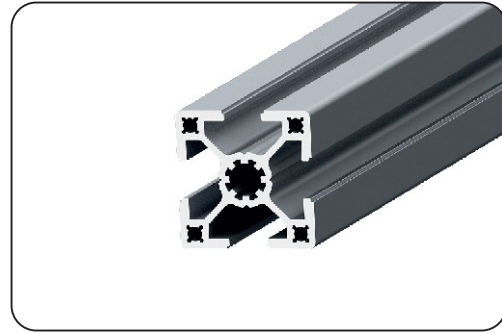
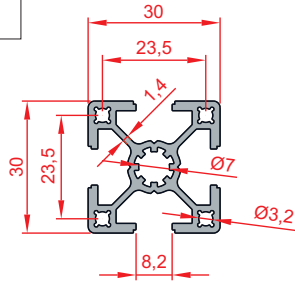
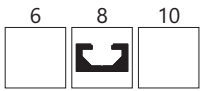

Stock Code	External Dimensions	Material	Moment of Inertia		Moments of Stength		Area	Mass
			$I_x$	$I_y$	$W_x$	$W_y$		
1.1.08.030030.03	30x30 Super Light	6063	$2.83\text{cm}^4$	$2.83\text{cm}^4$	$1.89\text{cm}^3$	$1.89\text{cm}^3$	$2.93\text{cm}^2$	0.79 Kg/m

Standard : 6010 mm Lmax : 7200 mm

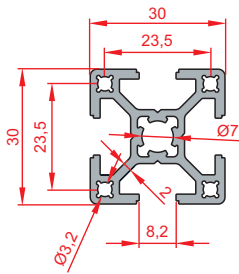

Stock Code	External Dimensions	Material	Moment of Inertia		Moments of Stength		Area	Mass
			$I_x$	$I_y$	$W_x$	$W_y$		
1.1.08.030030.02	30x30 Light	6063	$2.96\text{cm}^4$	$2.96\text{cm}^4$	$1.97\text{cm}^3$	$1.97\text{cm}^3$	$3.16\text{cm}^2$	0.86 Kg/m
<b>NEW</b> 1.1.08.030030.02.01	30x30 Light Black Anodized	6063	$2.96\text{cm}^4$	$2.96\text{cm}^4$	$1.97\text{cm}^3$	$1.97\text{cm}^3$	$3.16\text{cm}^2$	0.86 Kg/m

Standard : 6010 mm Lmax : 7200 mm

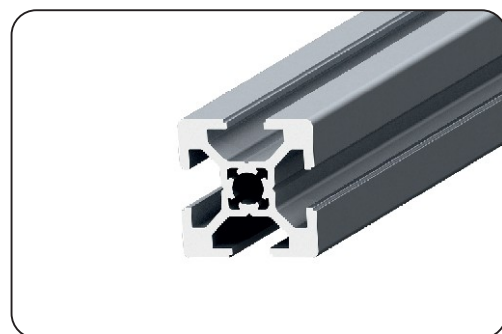
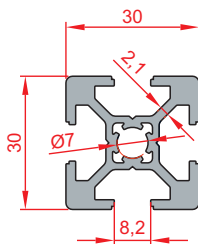

Stock Code	External Dimensions	Material	Moment of Inertia		Moments of Stength		Area	Mass
			$I_x$	$I_y$	$W_x$	$W_y$		
1.1.08.030030.01	30x30 Heavy Profile	6063	$3.56\text{cm}^4$	$3.56\text{cm}^4$	$2.38\text{cm}^3$	$2.38\text{cm}^3$	$3.63\text{cm}^2$	0.98 Kg/m

Standard : 6010 mm Lmax : 7200 mm

**Using Area**

These series, often used in manufacturing machinery cabins, are also preferred in lighter construction applications and making of boards and display booths.

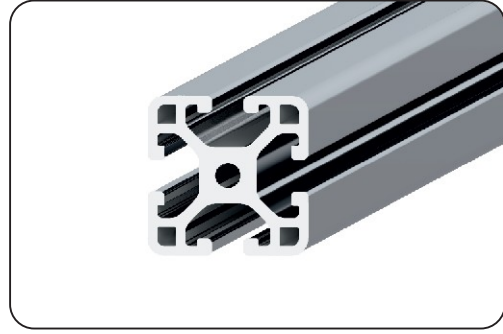
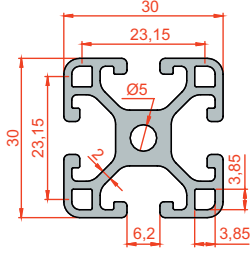
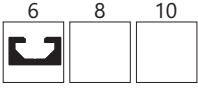

Stock Code	External Dimensions	Material	Moment of Inertia		Moments of Stength		Area	Mass
			$I_x$	$I_y$	$W_x$	$W_y$		
1.1.06.030030.02.1	30x30 Light Prf Special Series	6063 T5	$3.72\text{cm}^4$	$3.72\text{cm}^2$	$1.86\text{cm}^2$	$1.86\text{cm}^2$	$4.24\text{cm}^2$	0.94 Kg/m

Standard : 6010 mm Lmax : 7200 mm

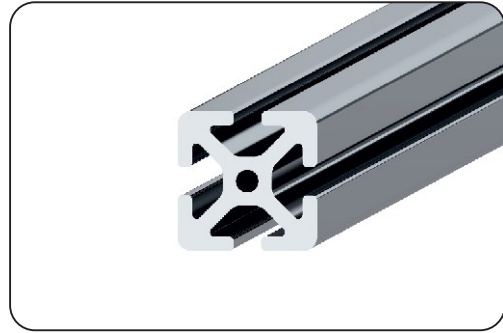
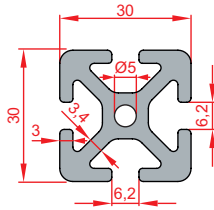
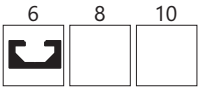

Kod	Ürün Adı	Malzeme	Atalet Momenti		Mukavemet Momenti		Alan	Kütle
			$I_x$	$I_y$	$W_x$	$W_y$		
1.1.06.030030.01.1	30x30 Ağır Profil Özel Seri	6063	$4.21\text{cm}^4$	$4.21\text{cm}^4$	$2.81\text{cm}^3$	$2.81\text{cm}^3$	$5.11\text{cm}^2$	1.28 Kg/m

Standart : 6010 mm Lmax : 7200 mm

### Using Area

Preferred in main connections of light constructions and slide door proslotions of cabins. Areas of application include test desks, automation groups and miniature conveyor.

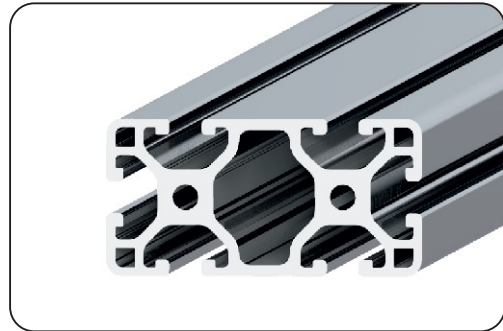
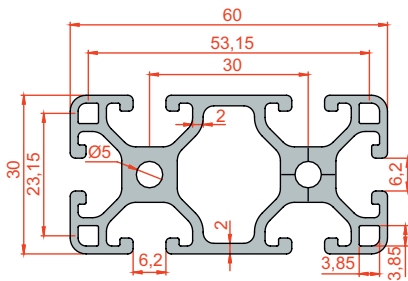

Stock Code	External Dimensions	Material	Moment of Inertia		Moments of Stength		Area	Mass
			$I_x$	$I_y$	$W_x$	$W_y$		
1.1.06.030060.02.1	30x60 Light Prf Special Series	6063 T5	$7.99\text{cm}^4$	$27.23\text{cm}^4$	$3.99\text{cm}^3$	$13.61\text{cm}^3$	$10.89\text{cm}^2$	2.93 Kg/m

Standard : 6010 mm Lmax : 7200 mm

### Using Area

Ensures wide connection thanks to triple slot feature. Machine frames can be used as upper and side body;while conveyor frame can serve as main body profile.



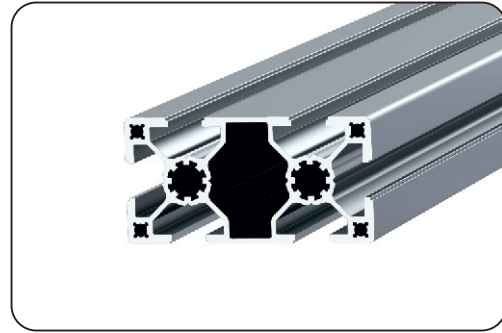
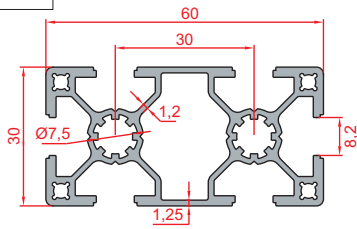

Stock Code	External Dimensions	Material	Moment of Inertia		Moments of Stength		Area	Mass
			$I_x$	$I_y$	$W_x$	$W_y$		
1.1.08.030060.03	30x60 Super Light	6063	$4.74\text{cm}^4$	$18.18\text{cm}^4$	$3.16\text{cm}^3$	$6.06\text{cm}^3$	$4.63\text{cm}^2$	1.26Kg/m

Standard : 6010 mm Lmax : 7200 mm

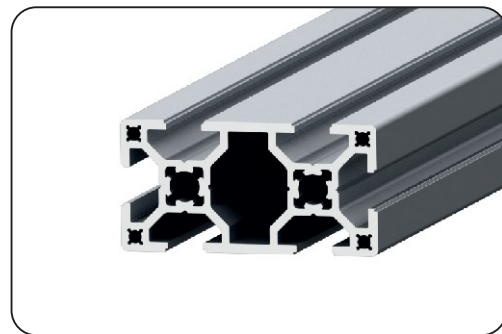
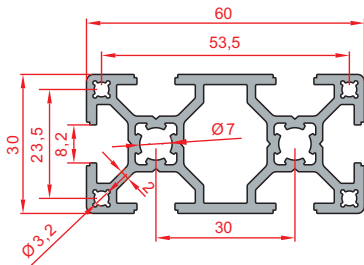

Stock Code	External Dimensions	Material	Moment of Inertia		Moments of Stength		Area	Mass
			$I_x$	$I_y$	$W_x$	$W_y$		
1.1.08.030060.02	30x60	6063	$5.46\text{cm}^4$	$20.11\text{cm}^4$	$3.64\text{cm}^3$	$6.70\text{cm}^3$	$5.59\text{cm}^2$	1.51 Kg/m

Standard : 6010 mm Lmax : 7200 mm

**Using Area**

Preferred in main connections of light constructions and slide door proslotions of cabins. Areas of application include test desks, automation groups and miniature conveyor.

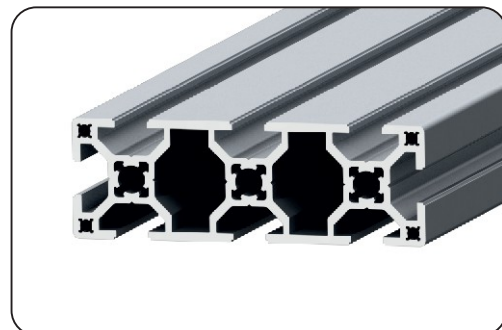
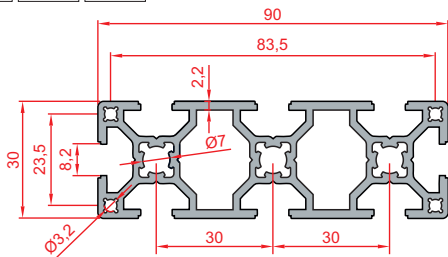

Stock Code	External Dimensions	Material	Moment of Inertia		Moments of Stength		Area	Mass
			$I_x$	$I_y$	$W_x$	$W_y$		
1.1.08.030090.02	30x90	6063	$7.96\text{cm}^4$	$62.43\text{cm}^4$	$5.31\text{cm}^3$	$13.87\text{cm}^3$	$8.01\text{cm}^2$	2.17 Kg/m

Standard : 6010 mm Lmax : 7200 mm

**Using Area**

Ensures wide connection thanks to triple slot feature. Machine frames can be used as upper and side body;while conveyor frame can serve as main body profile.

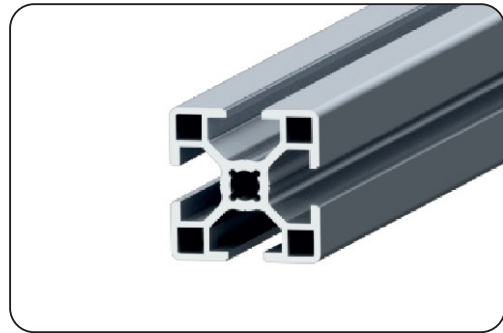
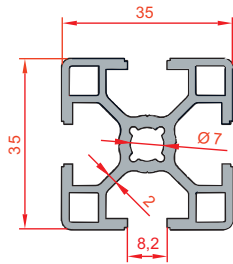

**35x35 Industrial Light Profile**

Code: 1.1.08.035035.02

Available for use in light machine constructions and protection cabins.

Stock Code	External Dimensions	Material	Moment of Inertia		Moments of Stength		Area	Mass
			$I_x$	$I_y$	$W_x$	$W_y$		
1.1.08.035035.02	35x35 Light	6063	$4.53\text{cm}^4$	$4.53\text{cm}^4$	$2.59\text{cm}^3$	$2.59\text{cm}^3$	$3.66\text{cm}^2$	0.99 Kg/m

Standard : 6010 mm Lmax : 7200 mm

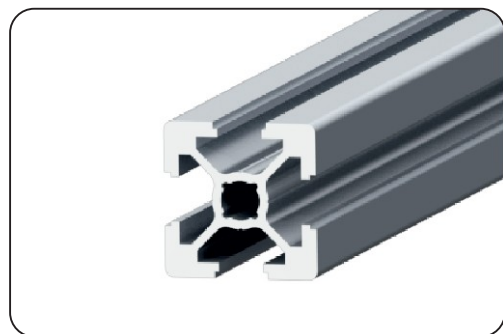
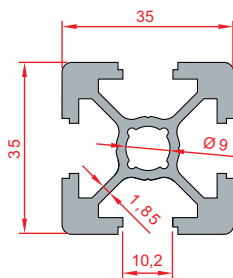

**35x35 Industrial Heavy Profile**

Code: 1.1.10.035035.01

Void-free sectional design enables use in middle-loading constructions and assembly line desks. After assembly, the unused slot and head are covered to ensure stylish view.

Stock Code	External Dimensions	Material	Moment of Inertia		Moments of Stength		Area	Mass
			$I_x$	$I_y$	$W_x$	$W_y$		
1.1.10.035035.01	35x35 Heavy	6063	$6.57\text{cm}^4$	$6.57\text{cm}^4$	$3.76\text{cm}^3$	$3.76\text{cm}^3$	$4.70\text{cm}^2$	1.27 Kg/m

Standard : 6010 mm Lmax : 7200 mm

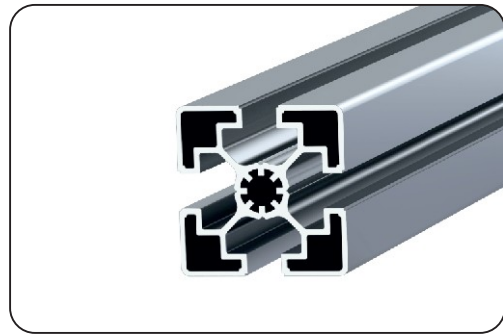
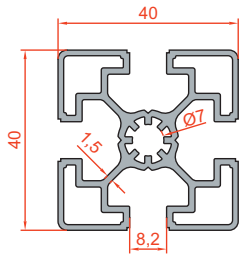

Stock Code	External Dimensions	Material	Moment of Inertia		Moments of Strength		Area	Mass
			$I_x$	$I_y$	$W_x$	$W_y$		
1.1.08.040040.03	40x40 Super Light (K8)	6063	$6.50\text{cm}^4$	$6.50\text{cm}^4$	$3.25\text{cm}^3$	$3.25\text{cm}^3$	$4.27\text{cm}^2$	1.16 Kg/m

Standard : 6010 mm Lmax : 7200 mm

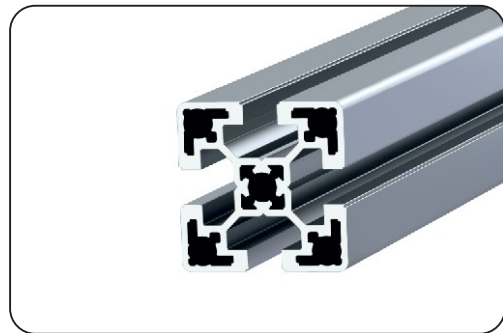
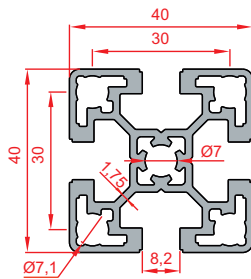

Stock Code	External Dimensions	Material	Moment of Inertia		Moments of Strength		Area	Mass
			$I_x$	$I_y$	$W_x$	$W_y$		
1.1.08.040040.02	40x40 Light (K8)	6063	$8.49\text{cm}^4$	$8.49\text{cm}^4$	$4.25\text{cm}^3$	$4.25\text{cm}^3$	$5.40\text{cm}^2$	1.46 Kg/m

Standard : 6010 mm Lmax : 7200 mm

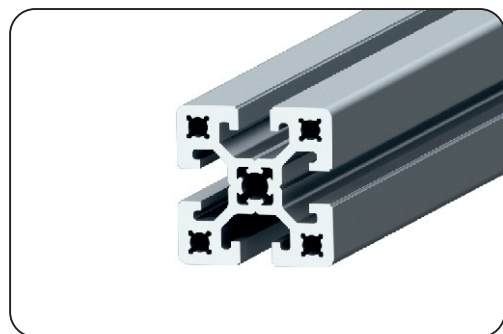
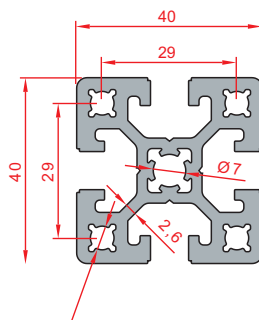

Stock Code	External Dimensions	Material	Moment of Inertia		Moments of Strength		Area	Mass
			$I_x$	$I_y$	$W_x$	$W_y$		
1.1.08.040040.01	40x40 Heavy (K8)	6063	$12.07\text{cm}^4$	$12.07\text{cm}^4$	$6.03\text{cm}^3$	$6.03\text{cm}^3$	$7.32\text{cm}^2$	1.99 Kg/m

Standard : 6010 mm Lmax : 7200 mm

**Using Area**

Preferred in machine frames requiring resistance and in feet group of conveyors subject to load. Sectional structure provides higher resistant compared to profiles of similar size.

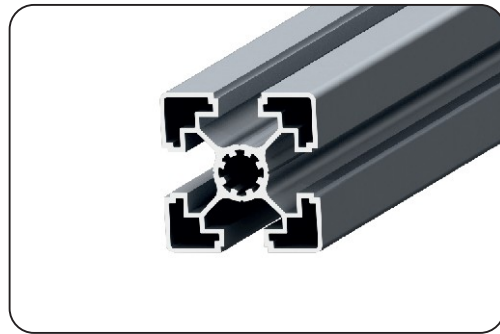
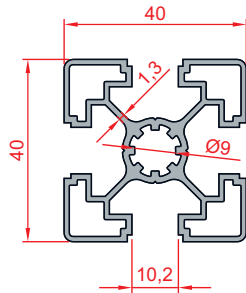
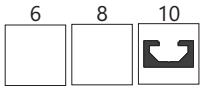

Stock Code	External Dimensions	Material	Moment of Inertia		Moments of Strength		Area	Mass
			$I_x$	$I_y$	$W_x$	$W_y$		
1.1.10.040040.03	40x40 Super Light (K10)	6063	$5.78\text{cm}^4$	$5.78\text{cm}^4$	$2.89\text{cm}^3$	$2.89\text{cm}^3$	$3.81\text{cm}^2$	1.03Kg/m

Standard : 6010 mm Lmax : 7200 mm

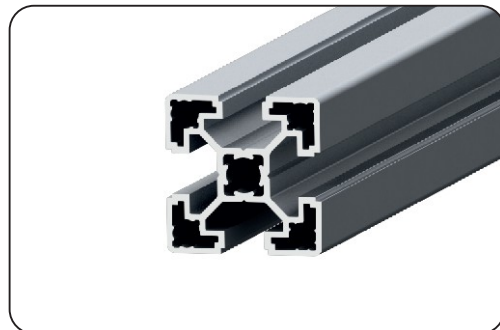
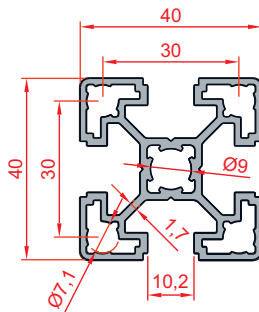
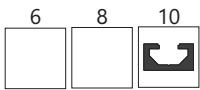

Stock Code	External Dimensions	Material	Moment of Inertia		Moments of Strength		Area	Mass
			$I_x$	$I_y$	$W_x$	$W_y$		
1.1.10.040040.02	40x40 Light (K10)	6063	$7.10\text{cm}^4$	$7.10\text{cm}^4$	$3.55\text{cm}^3$	$3.55\text{cm}^3$	$4.49\text{cm}^2$	1.22Kg/m
 1.1.10.040040.02.01	40x40 Light(K10)Black Anodized	6063	$7.10\text{cm}^4$	$7.10\text{cm}^4$	$3.55\text{cm}^3$	$3.55\text{cm}^3$	$4.49\text{cm}^2$	1.22Kg/m

Standard : 6010 mm Lmax : 7200 mm

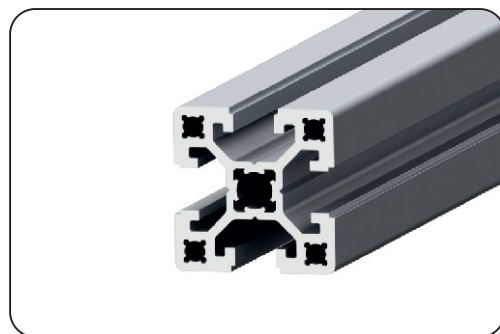
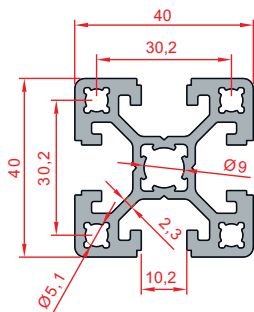

Stock Code	External Dimensions	Material	Moment of Inertia		Moments of Strength		Area	Mass
			$I_x$	$I_y$	$W_x$	$W_y$		
1.1.10.040040.01	40x40 Heavy (K10)	6063	$10.37\text{cm}^4$	$10.37\text{cm}^4$	$5.19\text{cm}^3$	$5.19\text{cm}^3$	$6.12\text{cm}^2$	1.66 Kg/m

Standard : 6010 mm Lmax : 7200 mm

Using Area

Can be used in light machine constructions and protection cabin proslotion. Avoids unnecessary costs in applications with light series profiles.

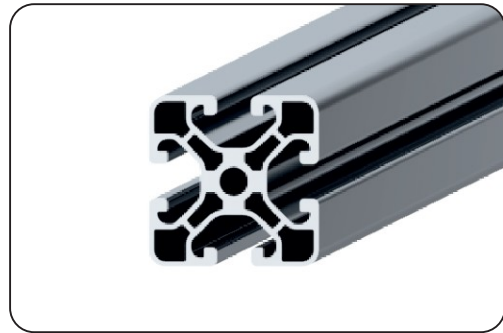
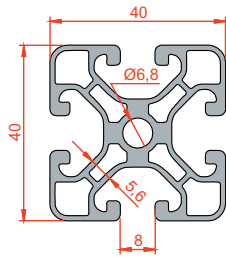
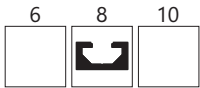

**40x40 Super Light Sigma Profile Special Series**

Code: 1.1.08.040040.03.1

Preferred in machine frames requiring resistance and in feet group of conveyors subject to load. Sectional structure provides higher resistant compared to profiles of similar size.

Stock Code	External Dimensions	Material	Moment of Inertia		Moments of Stength		Area	Mass
			I <sub>x</sub>	I <sub>y</sub>	W <sub>x</sub>	W <sub>y</sub>		
1.1.08.040040.03.1	40x40 Süper Light	6063	7.57cm <sup>4</sup>	7.57cm <sup>4</sup>	5.04cm <sup>3</sup>	5.04cm <sup>3</sup>	5.17cm <sup>2</sup>	1.40 Kg/m

Standart : 6010 mm Lmax : 7200 mm

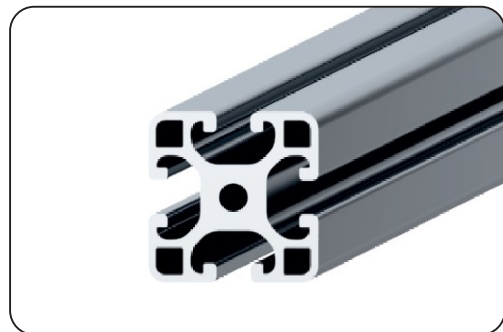
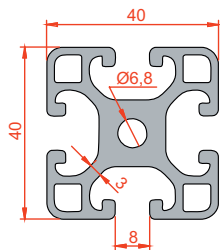

**40x40 Light Sigma Profile Special Series**

Code: 1.1.08.040040.02.1

Preferred in machine frames requiring resistance and in feet group of conveyors subject to load. Sectional structure provides higher resistant compared to profiles of similar size.

Stock Code	External Dimensions	Material	Moment of Inertia		Moments of Stength		Area	Mass
			I <sub>x</sub>	I <sub>y</sub>	W <sub>x</sub>	W <sub>y</sub>		
1.1.08.040040.02.1	40x40 Light	6063	12.86cm <sup>4</sup>	12.86cm <sup>4</sup>	8.57cm <sup>2</sup>	8.57cm <sup>2</sup>	8.57cm <sup>2</sup>	1.77 Kg/m

Standart : 6010 mm Lmax : 7200 mm

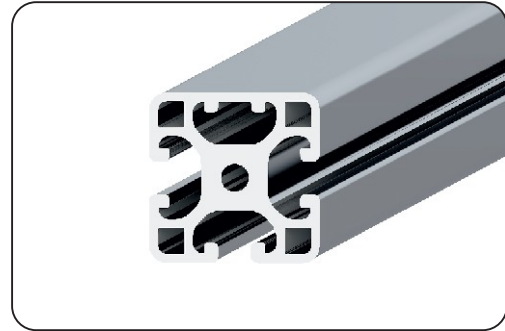
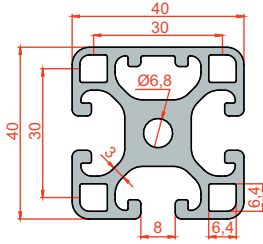
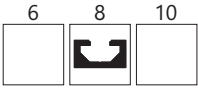

**40x40 Single Surface Closed Sigma Profile Special Series**

Code: 1.1.08.040040.05.1

Where profile channels must be closed and aesthetic appearance in preferred applications is suitable for use.

Stock Code	External Dimensions	Material	Moment of Inertia		Moments of Stength		Area	Mass
			$I_x$	$I_y$	$W_x$	$W_y$		
1.1.08.040040.05.1	40x40 Single Face Cup Special Ser	6063 T5	21.35cm <sup>4</sup>	17.40cm <sup>2</sup>	10.68cm <sup>2</sup>	8.70cm <sup>2</sup>	13.98cm <sup>2</sup>	3.76 Kg/m

Standart : 6010 mm Lmax : 7200 mm

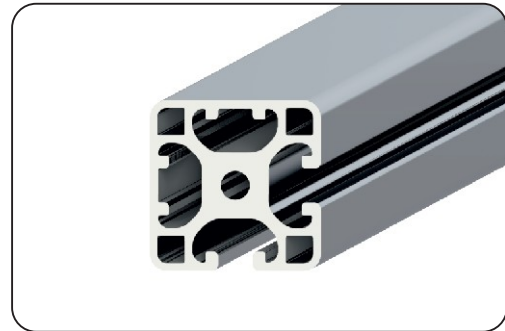
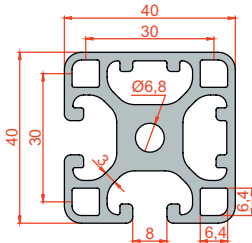
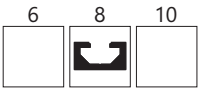

**40x40 Double Surface Closed Sigma Profile Special Series**

Code: 1.1.08.040040.05.2

It is suitable for use where profile channels should be closed and in applications where aesthetic appearance is preferred.

Stock Code	External Dimensions	Material	Moment of Inertia		Moments of Stength		Area	Mass
			$I_x$	$I_y$	$W_x$	$W_y$		
1.1.08.040040.05.2	40x40 Çift Yüz Kap Öz. Ser	6063 T5	21.37m <sup>4</sup>	23.81cm <sup>4</sup>	10.68cm <sup>3</sup>	11.91cm <sup>3</sup>	17.47cm <sup>2</sup>	4.70 Kg/m

Standart : 6010 mm Lmax : 7200 mm

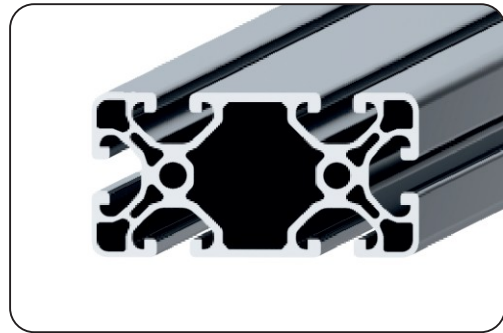
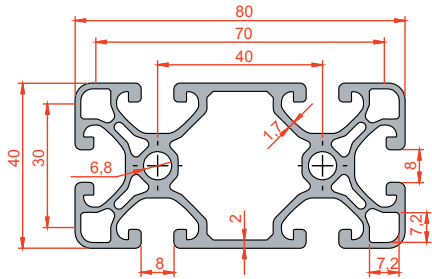
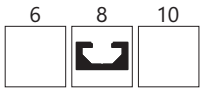

**40x80 Super Light Sigma Profile Special Series**

Code: 1.1.08.040080.03.1

Can be preferred in side connections of machine frames, resistant constructions, line groups and bodies with pneumatic connection.

Stock Code	External Dimensions	Material	Moment of Inertia		Moments of Stength		Area	Mass
			$I_x$	$I_y$	$W_x$	$W_y$		
1.1.08.040080.03.1	40x80 Spr Lght Prf Sp Ser	6063 T5	22.79cm <sup>4</sup>	64.82cm <sup>2</sup>	15.19cm <sup>2</sup>	43.21cm <sup>2</sup>	17.77cm <sup>2</sup>	2.47 Kg/m

Standart : 6010 mm Lmax : 7200 mm

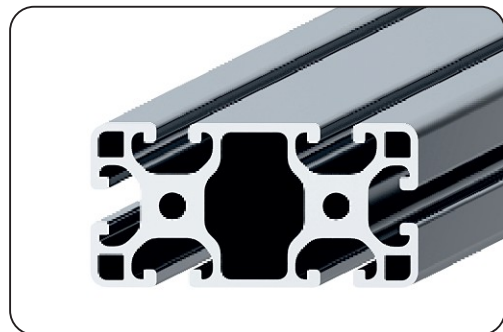
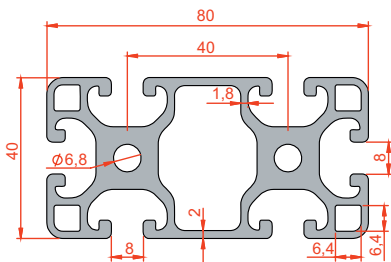

**40x80 Light Sigma Profile Special Series**

Code: 1.1.08.040080.02.1

It can be preferred for side connections of machine chassis, strong constructions, line groups and pneumatically connected bodies.

Stock Code	External Dimensions	Material	Moment of Inertia		Moments of Stength		Area	Mass
			$I_x$	$I_y$	$W_x$	$W_y$		
1.1.08.040080.02.1	40x80 Lght Prf Sp Ser	6063 T5	29.8cm <sup>4</sup>	70.15cm <sup>4</sup>	19.2cm <sup>3</sup>	46.77cm <sup>3</sup>	18.65cm <sup>2</sup>	3.09 Kg/m

Standart : 6010 mm Lmax : 7200 mm

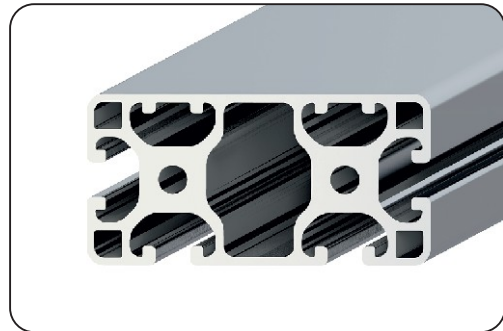
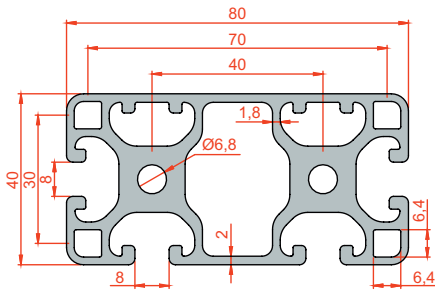

**40x80 Single Surface Closed Sigma Profile Special Series**

Code: 1.1.08.040080.05.1

It can be preferred for side connections of machine chassis, strong constructions, line groups and bodies with pneumatic connection.

Stock Code	External Dimensions	Material	Moment of Inertia		Moments of Stength		Area	Mass
			I <sub>x</sub>	I <sub>y</sub>	W <sub>x</sub>	W <sub>y</sub>		
1.1.08.040080.05.1	40x80 Single Surface Cls Prf Spc Ser	6063 T5	47.80cm <sup>4</sup>	150.62cm <sup>2</sup>	23.90cm <sup>2</sup>	75.31cm <sup>2</sup>	37.26cm <sup>2</sup>	10.02 Kg/m

Standart : 6010 mm Lmax : 7200 mm

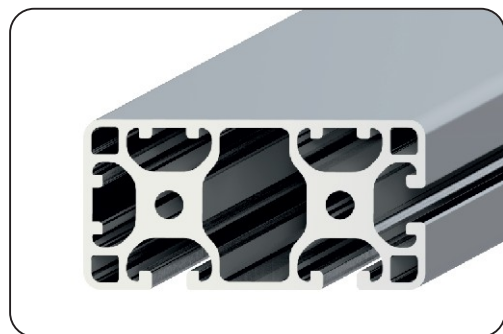
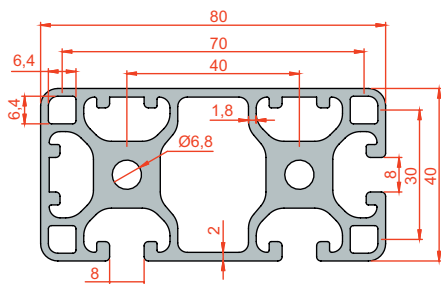

**40x80 Double Surface Closed Sigma Profile Special Series**

Code: 1.1.08.040080.05.2

It is suitable for use where profile channels must be closed and in applications where aesthetic appearance is preferred.

Stock Code	External Dimensions	Material	Moment of Inertia		Moments of Stength		Area	Mass
			I <sub>x</sub>	I <sub>y</sub>	W <sub>x</sub>	W <sub>y</sub>		
1.1.08.040080.05.2	40x80 Double Surface Closed Prf Spc Ser	6063 T5	49.02cm <sup>4</sup>	186.42cm <sup>4</sup>	24.51cm <sup>3</sup>	93.31cm <sup>3</sup>	40.87cm <sup>2</sup>	10.99 Kg/m

Standart : 6010 mm Lmax : 7200 mm



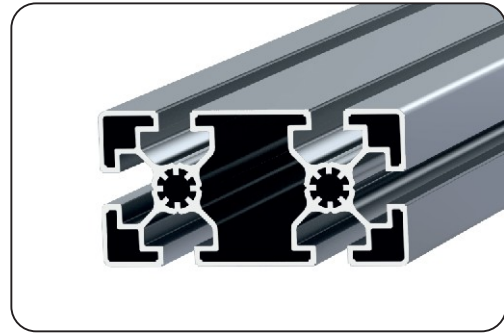
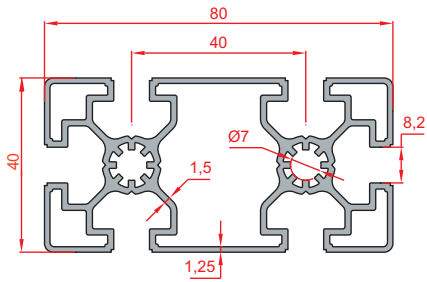

Stock Code	External Dimensions	Material	Moment of Inertia		Moments of Strength		Area	Mass
			$I_x$	$I_y$	$W_x$	$W_y$		
1.1.08.040080.03	40x80 Super Light (K8)	6063	$11.54\text{cm}^4$	$46.89\text{cm}^4$	$5.77\text{cm}^3$	$11.72\text{cm}^3$	$7.07\text{cm}^2$	1.92 Kg/m

Standard : 6010 mm Lmax : 7200 mm

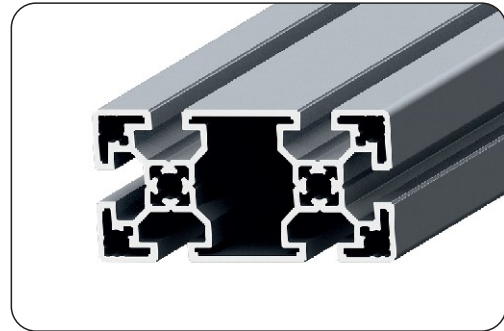
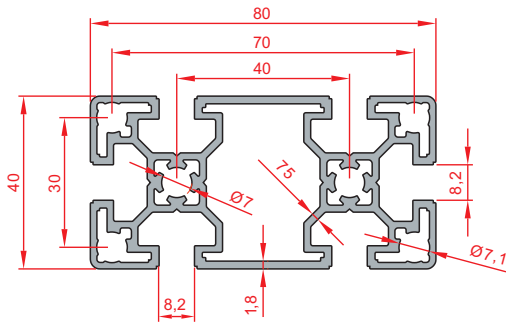

Stock Code	External Dimensions	Material	Moment of Inertia		Moments of Strength		Area	Mass
			$I_x$	$I_y$	$W_x$	$W_y$		
1.1.08.040080.02	40x80 Light (K8)	6063	$14.44\text{cm}^4$	$56.51\text{cm}^4$	$7.22\text{cm}^3$	$14.13\text{cm}^3$	$8.48\text{cm}^2$	2.30 Kg/m

Standard 6010 mm Lmax : 7200 mm

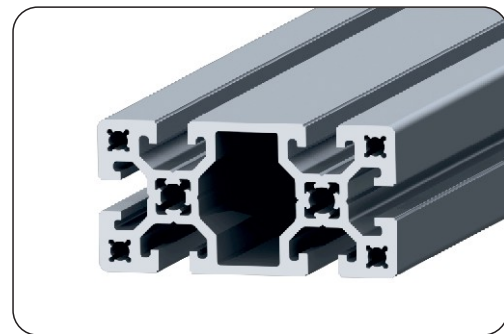
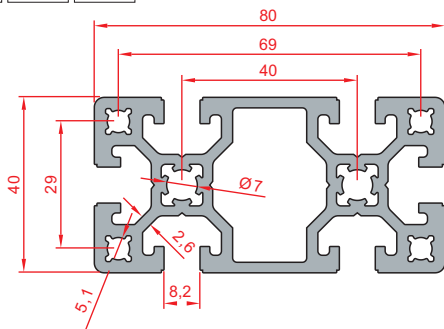

Stock Code	External Dimensions	Material	Moment of Inertia		Moments of Strength		Area	Mass
			$I_x$	$I_y$	$W_x$	$W_y$		
1.1.08.040080.01	40x80 Heavy (K8)	6063	$20.91\text{cm}^4$	$82.30\text{cm}^4$	$10.45\text{cm}^3$	$20.58\text{cm}^3$	$11.91\text{cm}^2$	3.23 Kg/m

Standard : 6010 mm Lmax : 7200 mm

**Using Area**

Can be preferred in side connections of machine frames, resistant constructions, line groups and bodies with pneumatic connection.

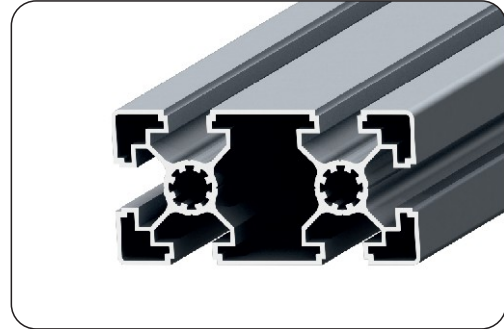
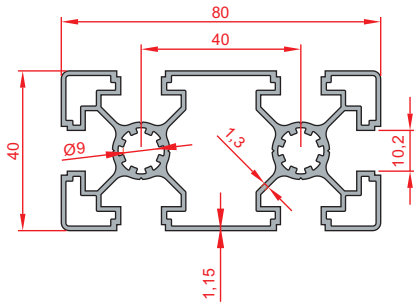
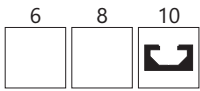

Stock Code	External Dimensions	Material	Moment of Inertia		Moments of Strength		Area	Mass
			$I_x$	$I_y$	$W_x$	$W_y$		
1.1.10.040080.03	40x80 Super Light (K10)	6063	10.24cm <sup>4</sup>	41.83cm <sup>4</sup>	5.12cm <sup>3</sup>	10.46cm <sup>3</sup>	6.38 cm <sup>2</sup>	1.73 Kg/m

Standard : 6010 mm Lmax : 7200 mm

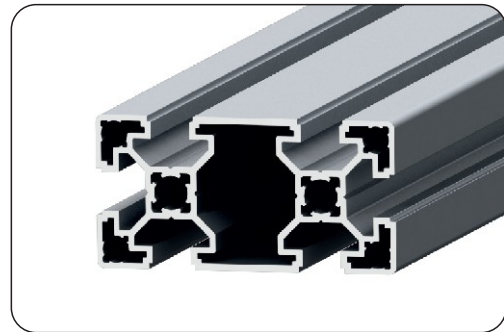
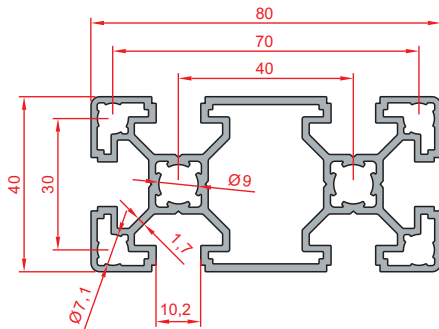
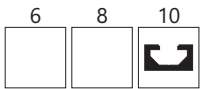

Stock Code	External Dimensions	Material	Moment of Inertia		Moments of Strength		Area	Mass
			$I_x$	$I_y$	$W_x$	$W_y$		
1.1.10.040080.02	40x80 Light (K10)	6063	13.13cm <sup>4</sup>	49.95cm <sup>4</sup>	6.57cm <sup>3</sup>	12.49cm <sup>3</sup>	7.67 cm <sup>2</sup>	2.08 Kg/m

Standard : 6010 mm Lmax : 7200 mm

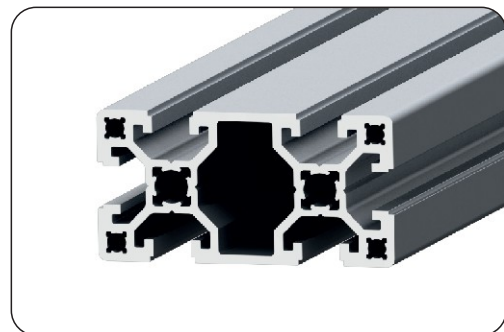
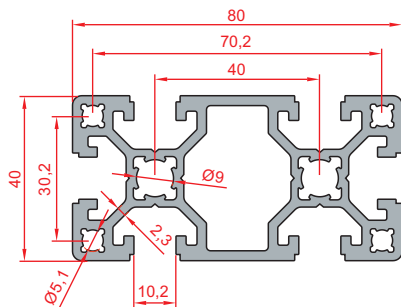
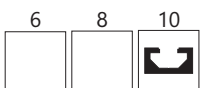

Stock Code	External Dimensions	Material	Moment of Inertia		Moments of Strength		Area	Mass
			$I_x$	$I_y$	$W_x$	$W_y$		
1.1.10.040080.01	40x80 Heavy (K10)	6063	18.51cm <sup>4</sup>	69.52cm <sup>4</sup>	9.26cm <sup>3</sup>	17.38cm <sup>3</sup>	10.23 cm <sup>2</sup>	2.77 Kg/m

Standard : 6010 mm Lmax : 7200 mm

Using Area

Can be preferred in side connections of machine frames, resistant constructions, line groups and bodies with pneumatic connection.

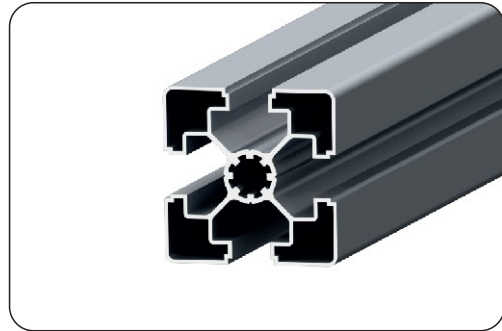
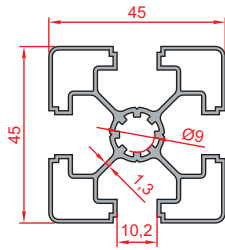
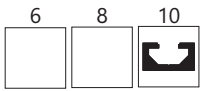

**45x45 Industrial Ultra Super Light Profile**

Code: 1.1.10.045045.09

Thanks to super-thin wall structure, it is preferred on frames not subject to load and on closing cabins of machines.

Stock Code	External Dimensions	Material	Moment of Inertia		Moments of Stength		Area	Mass
			$I_x$	$I_y$	$W_x$	$W_y$		
1.1.10.045045.09	45x45 Ultra Super Light	6063	$6.64\text{cm}^4$	$6.64\text{cm}^4$	$2.95\text{cm}^3$	$2.95\text{cm}^3$	$3.54\text{cm}^2$	0.96 Kg/m

Standard : 6010 mm Lmax : 7200 mm

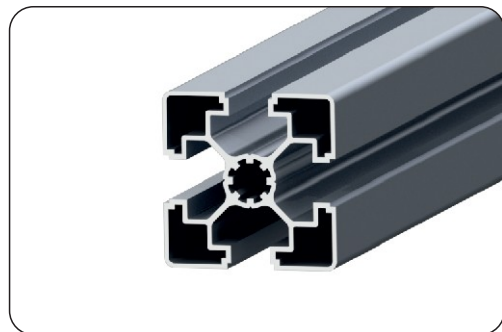
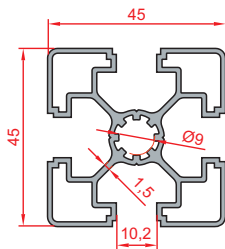

**45x45 Industrial Super Light Profil**

Code: 1.1.10.045045.03

Thanks to super-thin wall structure, it is preferred on frames not subject to load and on closing cabins of machines.

Stock Code	External Dimensions	Material	Moment of Inertia		Moments of Stength		Area	Mass
			$I_x$	$I_y$	$W_x$	$W_y$		
1.1.10.045045.03	45x45 Super Light	6063	$8.26\text{cm}^4$	$8.26\text{cm}^4$	$3.67\text{cm}^3$	$3.67\text{cm}^3$	$4.28\text{cm}^2$	1.16 Kg/m

Standard : 6010 mm Lmax : 7200 mm

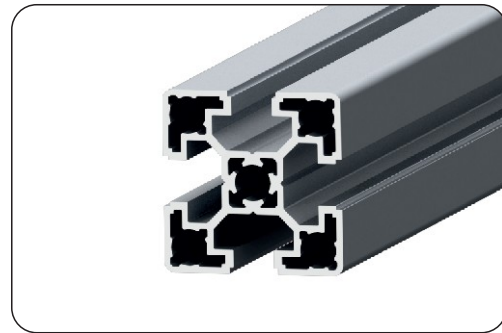
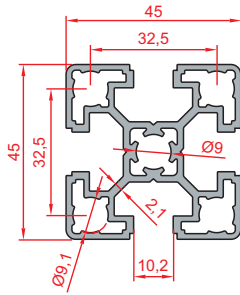
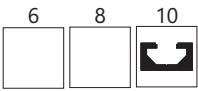

**45x45 Industrial Light Profile**

Code: 1.1.10.045045.02

Suitable for use in light frame constructions that do not require resistance, cabin applications, and proslotion of assembly and test benches.

Stock Code	External Dimensions	Material	Moment of Inertia		Moments of Stength		Area	Mass
			$I_x$	$I_y$	$W_x$	$W_y$		
1.1.10.045045.02	45x45 Light	6063	11.09cm <sup>4</sup>	11.09cm <sup>4</sup>	4.93cm <sup>3</sup>	4.93cm <sup>3</sup>	5.62cm <sup>2</sup>	1.52 Kg/m
 1.1.10.045045.02.01	45x45 Light Black Anodized	6063	11.09cm <sup>4</sup>	11.09cm <sup>4</sup>	4.93cm <sup>3</sup>	4.93cm <sup>3</sup>	5.62cm <sup>2</sup>	1.52 Kg/m

Standard : 6010 mm Lmax : 7200 mm

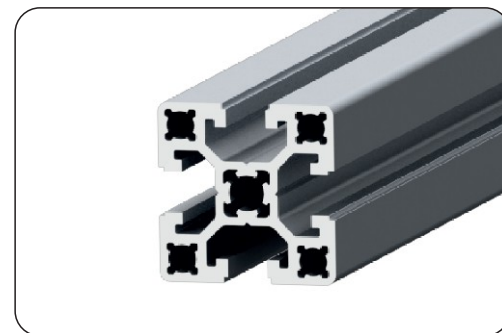
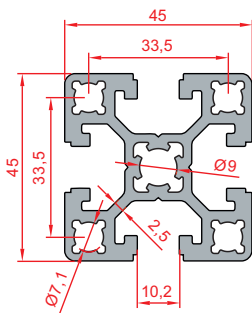

**45x45 Industrial Heavy Profile**

Code: 1.1.10.045045.01

Preferred for use on intermediate couplings of machine rames which require loading, as on automation processes and bodies with pneumatic connection

Stock Code	External Dimensions	Material	Moment of Inertia		Moments of Stength		Area	Mass
			$I_x$	$I_y$	$W_x$	$W_y$		
1.1.10.045045.01	45x45 Heavy	6063	15.65cm <sup>4</sup>	15.65cm <sup>4</sup>	6.95cm <sup>3</sup>	6.95cm <sup>3</sup>	7.63cm <sup>2</sup>	2.07 Kg/m

Standard : 6010 mm Lmax : 7200 mm

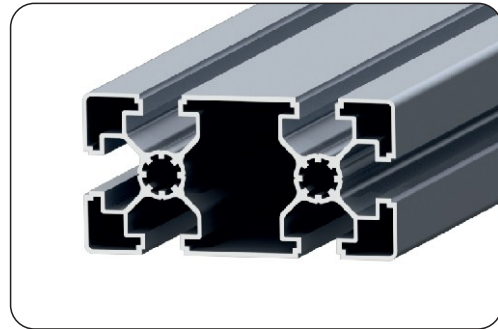
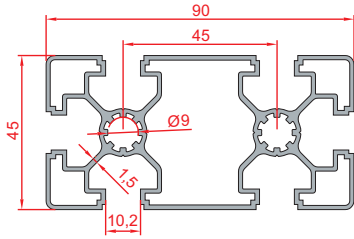
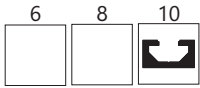

**45x90 Industrial Super Light Profile**

Code: 1.1.10.045090.03

Thanks to super-thinwall structure, it is preferred on frames not subject to load and on closing cabins of machines.

Stock Code	External Dimensions	Material	Moment of Inertia		Moments of Stength		Area	Mass
			$I_x$	$I_y$	$W_x$	$W_y$		
1.1.10.045090.03	45x90 Super Light	6063	15.22cm <sup>4</sup>	59.21cm <sup>4</sup>	6.76cm <sup>3</sup>	13.16cm <sup>3</sup>	7.14cm <sup>2</sup>	1.94 Kg/m

Standard : 6010 mm Lmax : 7200 mm

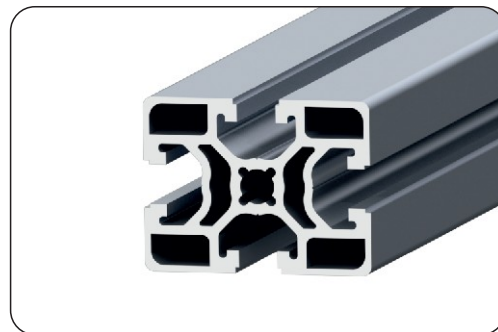
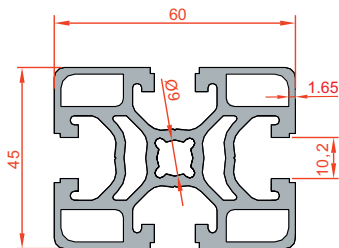

**45x60 Industrial Profile**

Code: 1.1.10.045060.01

Preferred for use in intermediate couplings of machine frames, resistant constructions, line groups, automation processes, bodies with pneumatic connections etc.

Stock Code	External Dimensions	Material	Moment of Inertia		Moments of Stength		Area	Mass
			$I_x$	$I_y$	$W_x$	$W_y$		
1.1.10.045060.01	45x60	6063	18.46cm <sup>4</sup>	31.30cm <sup>4</sup>	8.20cm <sup>3</sup>	10.43cm <sup>3</sup>	9.46cm <sup>2</sup>	2.56 Kg/m

Standard : 6010 mm Lmax : 7200 mm

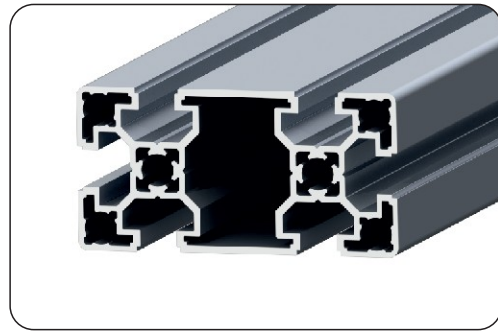
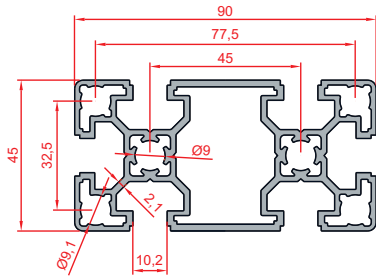
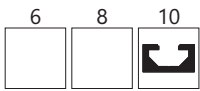

**45x90 Industrial Light Profile**

Code: 1.1.10.045090.02

Light series are preferred in automation applications with low vibration not exposed to load and lighter construction formations.

Stock Code	External Dimensions	Material	Moment of Inertia		Moments of Stength		Area	Mass
			$I_x$	$I_y$	$W_x$	$W_y$		
1.1.10.045090.02	45x90 Light	6063	20.74cm <sup>4</sup>	78.97cm <sup>4</sup>	9.22cm <sup>3</sup>	17.55cm <sup>3</sup>	9.63cm <sup>2</sup>	2.61 Kg/m

Standard : 6010 mm Lmax : 7200 mm

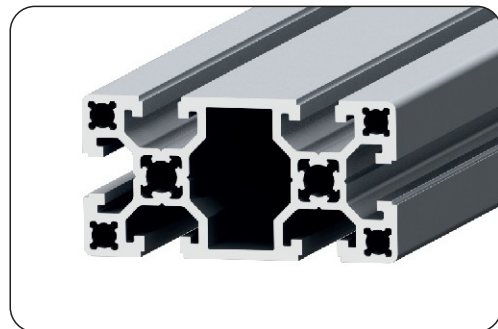
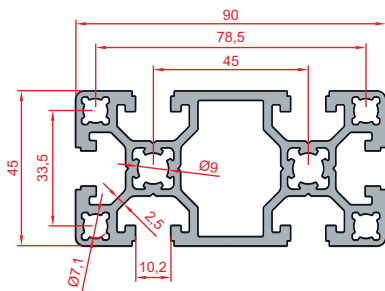

**45x90 Industrial Heavy Profil**

Code: 1.1.10.045090.01

Can be preferred in side connections of machine frames, resistant constructions, line groups and bodies with pneumatic connection.

Stock Code	External Dimensions	Material	Moment of Inertia		Moments of Stength		Area	Mass
			$I_x$	$I_y$	$W_x$	$W_y$		
1.1.10.045090.01	45x90 Heavy	6063	28.67cm <sup>4</sup>	108.14cm <sup>4</sup>	12.74cm <sup>3</sup>	24.03cm <sup>3</sup>	12.86cm <sup>2</sup>	3.48 Kg/m

Standard : 6010 mm Lmax : 7200 mm

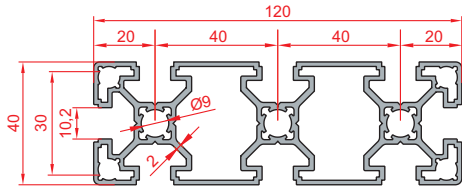
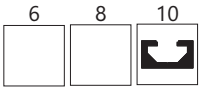

### 40x120 Industrial Super Light Profile

Code: 1.1.10.040120.03

Preferred for use on machine constructions subject to load and resistant frame applications. Triple slot ensures strong connection. Elegant view can be ensured by closing unused slots.

Stock Code	External Dimensions	Material	Moment of Inertia		Moments of Stength		Area	Mass
			$I_x$	$I_y$	$W_x$	$W_y$		
1.1.10.040120.03	40x120 Super Light	6063	$26.65\text{cm}^4$	$210.46\text{cm}^4$	$13.33\text{cm}^3$	$35.08\text{cm}^3$	$13.12\text{cm}^2$	2.92 Kg/m

Standard : 6010 mm Lmax : 7200 mm

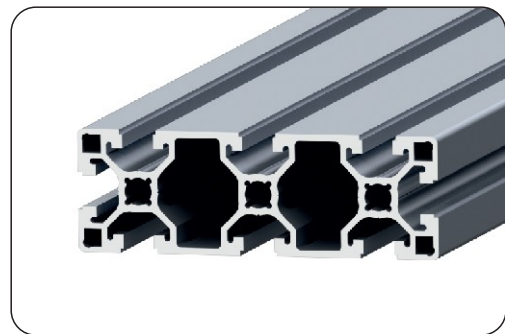
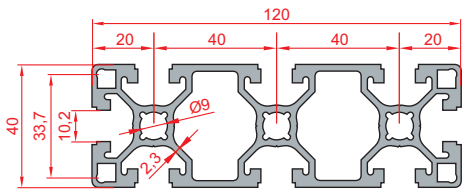
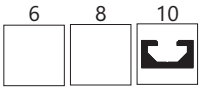

### 40x120 Industrial Profile

Code: 1.1.10.045180.01

Preferred for use on machine constructions subject to load and resistant frame applications. Triple slot ensures strong connection. Elegant view can be ensured by closing unused slots.

Stock Code	External Dimensions	Material	Moment of Inertia		Moments of Stength		Area	Mass
			$I_x$	$I_y$	$W_x$	$W_y$		
1.1.10.040120.02	40x120	6063	$26.65\text{cm}^4$	$210.46\text{cm}^4$	$13.33\text{cm}^3$	$35.08\text{cm}^3$	$14.34\text{cm}^2$	3.89 Kg/m

Standard : 6010 mm Lmax : 7200 mm

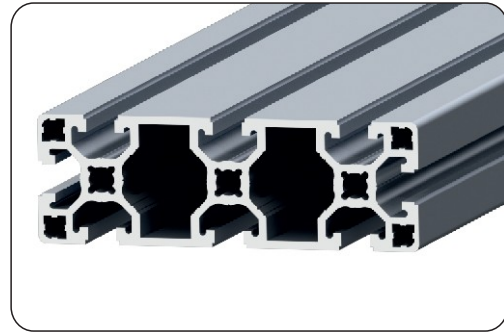
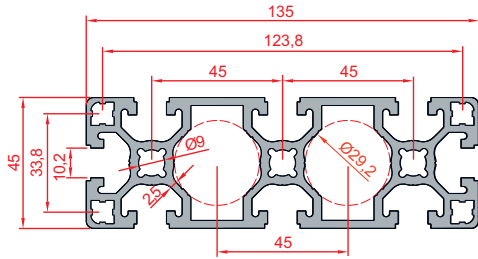
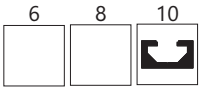

### 40x135 Industrial Profile

Code: 1.1.10.045135.02

Preferred for use in intermediate couplings of machine frames, resistant constructions, line groups, automation processes, bodies with pneumatic connections etc.

Stock Code	External Dimensions	Material	Moment of Inertia		Moments of Stength		Area	Mass
			$I_x$	$I_y$	$W_x$	$W_y$		
1.1.10.045135.02	45x135	6063	42.12cm <sup>4</sup>	329.17cm <sup>4</sup>	18.72cm <sup>3</sup>	48.77cm <sup>3</sup>	18.45cm <sup>2</sup>	5.00 Kg/m

Standard : 6010 mm Lmax : 7200 mm

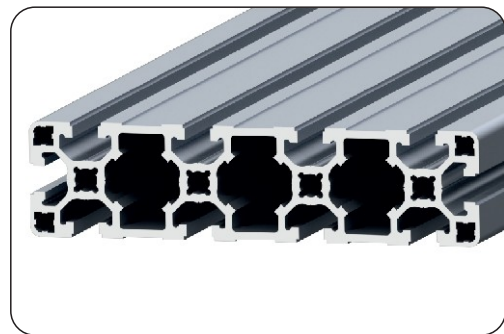
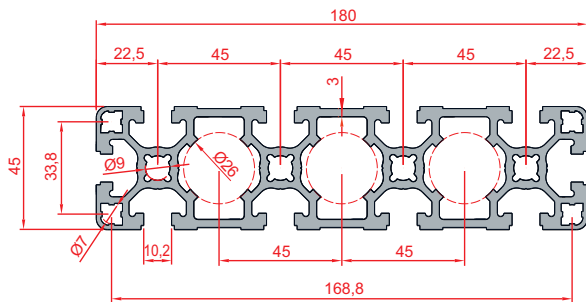
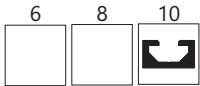

### 40x180 Industrial Profile

Code: 1.1.10.045180.01

Thanks to strong physical structure, these profile series are preferred on frame of machines that require resistance and on formations of side frames. Besides, they are available for assembly of 3 central linear ball-bearings of 26 mm diameter that provide slide bearing feature for the design.

Stock Code	External Dimensions	Material	Moment of Inertia		Moments of Stength		Area	Mass
			$I_x$	$I_y$	$W_x$	$W_y$		
1.1.10.045180.01	45x180	6063	57.23cm <sup>4</sup>	760.57cm <sup>4</sup>	25.44cm <sup>3</sup>	84.51cm <sup>3</sup>	25.25cm <sup>2</sup>	6.84 Kg/m

Standard : 6010 mm Lmax : 7200 mm



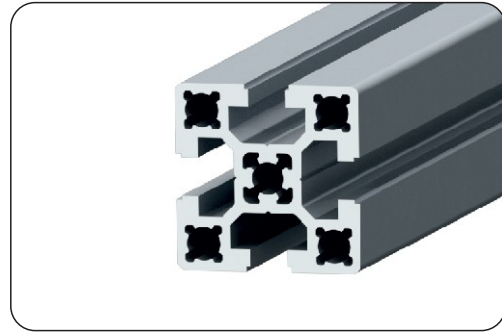
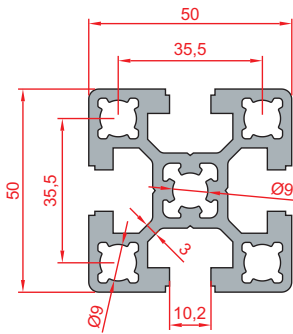
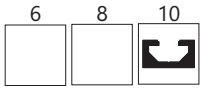

**50x50 Industrial Heavy Profile**

Code: 1.1.10.050050.01

These profile series are preferred on frameworks and side frames of strength-requiring machines for their strong physical structure.

Stock Code	External Dimensions	Material	Moment of Inertia		Moments of Stength		Area	Mass
			$I_x$	$I_y$	$W_x$	$W_y$		
1.1.10.050050.01	50x50 Heavy	6063	24.76 cm <sup>4</sup>	24.76 cm <sup>4</sup>	9.90cm <sup>3</sup>	9.90cm <sup>3</sup>	10.01cm <sup>2</sup>	2.71 Kg/m

Standard : 6010 mm Lmax : 7200 mm

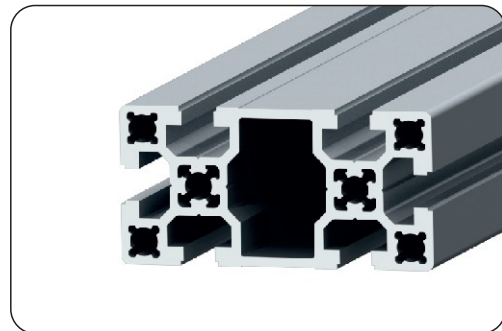
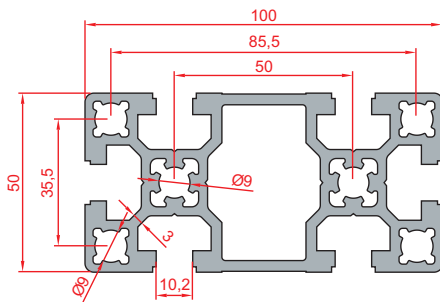

**50x100 Industrial Heavy Profile**

Code: 1.1.10.050100.01

These profile series are preferred in strength-requiring structures and machine body formations.

Stock Code	External Dimensions	Material	Moment of Inertia		Moments of Stength		Area	Mass
			$I_x$	$I_y$	$W_x$	$W_y$		
1.1.10.050100.01	50x100 Heavy	6063	44.86cm <sup>4</sup>	174.02cm <sup>4</sup>	17.95cm <sup>3</sup>	34.80cm <sup>3</sup>	16.79cm <sup>2</sup>	4.55 Kg/m

Standard : 6010 mm Lmax : 7200 mm

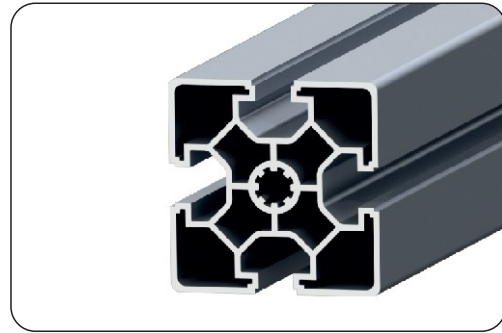
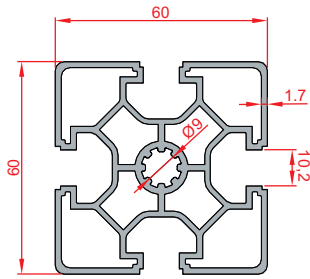
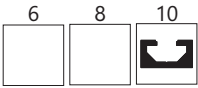

**60x60 Industrial Profile**

Code: 1.1.10.060060.02

These profile series can be used in areas where there is no loading, such as compartment poles, ceiling dressing frames, spot-bearing beams etc.

Stock Code	External Dimensions	Material	Moment of Inertia		Moments of Stength		Area	Mass
			$I_x$	$I_y$	$W_x$	$W_y$		
1.1.10.060060.02	60x60	6063	29.83cm <sup>4</sup>	29.83cm <sup>4</sup>	9.94cm <sup>3</sup>	9.94cm <sup>3</sup>	8.72cm <sup>2</sup>	2.36 Kg/m

Standard : 6010 mm Lmax : 7200 mm

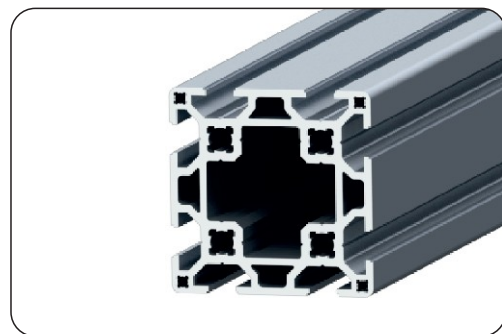
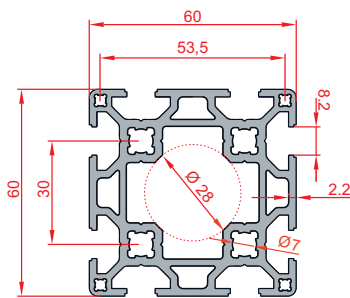

**60x60 Double Slot Industrial Profile**

Code: 1.1.08.060060.02

Areas of use include proslotion lines and main body formations of medium-load group constructions.

Stock Code	External Dimensions	Material	Moment of Inertia		Moments of Stength		Area	Mass
			$I_x$	$I_y$	$W_x$	$W_y$		
1.1.08.060060.02	60x60 With Double Slot	6063	41.02cm <sup>4</sup>	41.02cm <sup>4</sup>	13.67cm <sup>3</sup>	13.67cm <sup>3</sup>	11.07cm <sup>2</sup>	3.00 Kg/m

Standard : 6010 mm Lmax : 7200 mm

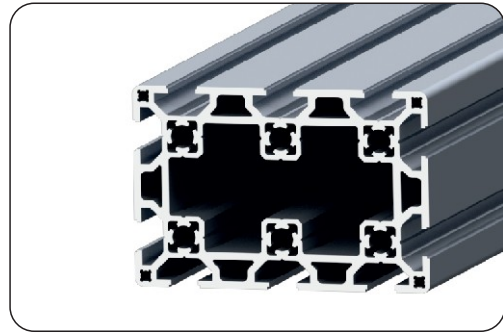
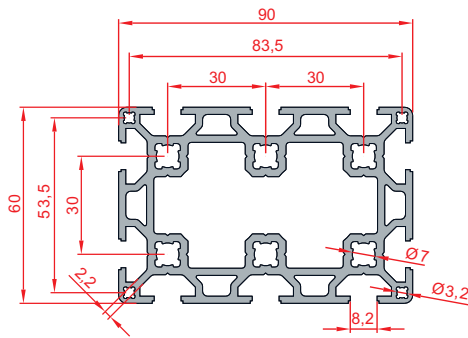
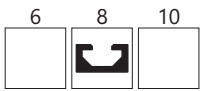

**60x60 Industrial Heavy Profile**

Code: 1.1.08.060090.01

Used as carrying profile on machine frames requiring high strength, and on larger constructions. Thanks to mechanical proslots mounted on the profile, it can be employed as frame for bedding axes.

Stock Code	External Dimensions	Material	Moment of Inertia		Moments of Stength		Area	Mass
			$I_x$	$I_y$	$W_x$	$W_y$		
1.1.08.060090.01	60x90 Heavy	6063	$64.63\text{cm}^4$	$134.72\text{cm}^4$	$21.55\text{cm}^3$	$29.94\text{cm}^3$	$16.01\text{cm}^2$	4.34 Kg/m

Standard : 6010 mm Lmax : 7200 mm

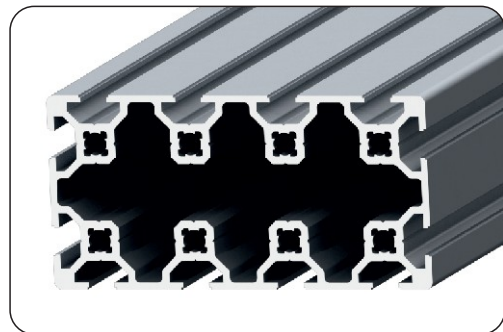
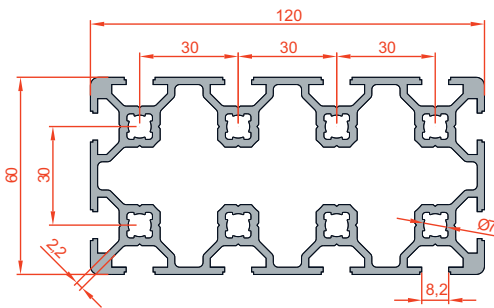

**60x120 Industrial Light Profile**

Code: 1.1.08.060120.02

Used as carrying body profile on machine frames requiring high strength, as as in larger constructions. Can also be used as bedding profile together with integrable mechanical proslots.

Stock Code	External Dimensions	Material	Moment of Inertia		Moments of Stength		Area	Mass
			$I_x$	$I_y$	$W_x$	$W_y$		
1.1.08.060120.02	60x120 Light	6063	$75.68\text{cm}^4$	$265.06\text{cm}^4$	$25.23\text{cm}^3$	$44.18\text{cm}^3$	$17.48\text{cm}^2$	4.74 Kg/m

Standard : 6010 mm Lmax : 7200 mm

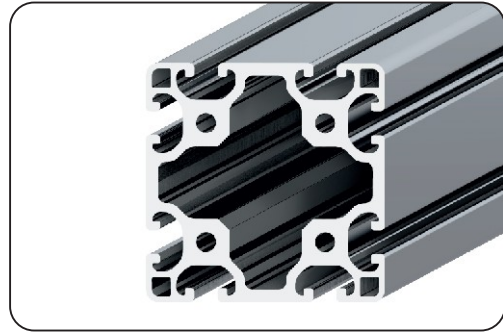
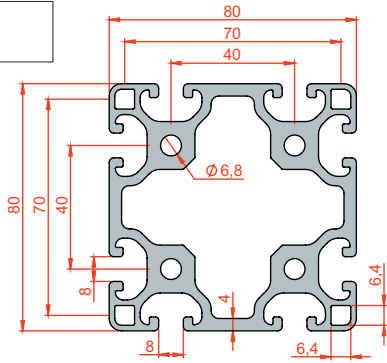
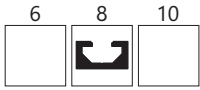

Stock Code	External Dimensions	Material	Moment of Inertia		Moments of Stength		Area	Mass
			$I_x$	$I_y$	$W_x$	$W_y$		
1.1.08.080080.02.1	80x80 Light Prf Spc Ser	6063 T5	225.01cm <sup>4</sup>	225.01cm <sup>2</sup>	56.25cm <sup>2</sup>	56.25cm <sup>2</sup>	49.18cm <sup>2</sup>	5.33 Kg/m

Standart : 6010 mm Lmax : 7200 mm

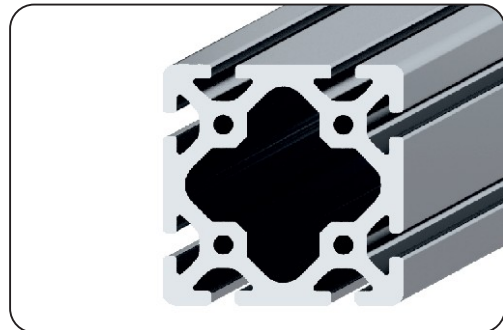
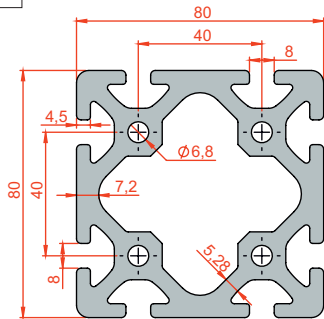
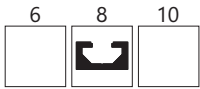

Stock Code	External Dimensions	Material	Moment of Inertia		Moments of Stength		Area	Mass
			$I_x$	$I_y$	$W_x$	$W_y$		
1.1.08.080080.01.1	80x80 Heavy Prf Spc Ser	6063 T5	295.49cm <sup>4</sup>	295.49cm <sup>2</sup>	73.87cm <sup>2</sup>	73.87cm <sup>2</sup>	76.01cm <sup>2</sup>	7.25 Kg/m

Standart : 6010 mm Lmax : 7200 mm

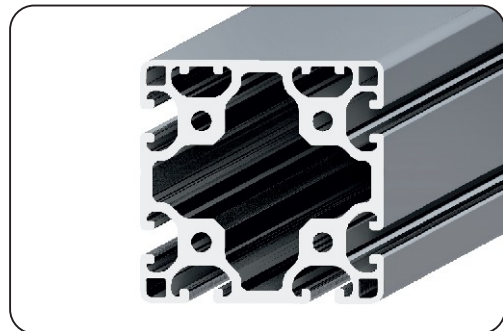
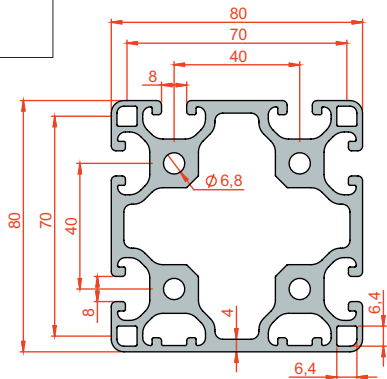

Stock Code	External Dimensions	Material	Moment of Inertia		Moments of Stength		Area	Mass
			$I_x$	$I_y$	$W_x$	$W_y$		
1.1.08.080080.05.1	80x80 Single Surface Closed Prf Spc Ser	6063 T5	263.65cm <sup>4</sup>	240.62cm <sup>4</sup>	131.83cm <sup>3</sup>	120.32cm <sup>3</sup>	52.85cm <sup>2</sup>	13.02 Kg/m

Standart : 6010 mm Lmax : 7200 mm

**Using Area**

**Light Series;** Can be used on poles of compartments with larger size, ceiling dressing frames and also as spot-bearing beams. These series of thin wall structure in wide category are preferred in areas without high loads.

**Heavy Series;** These profile series can meet required resistance at middle loading capacities and are preferred on bench bodies, machine frames and bearing platform beams.

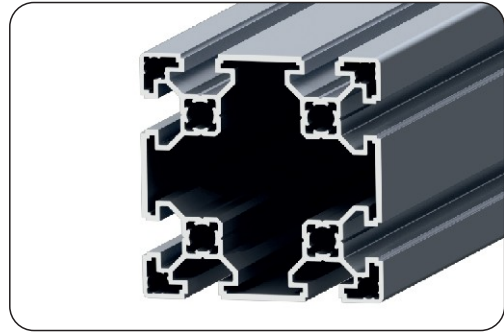
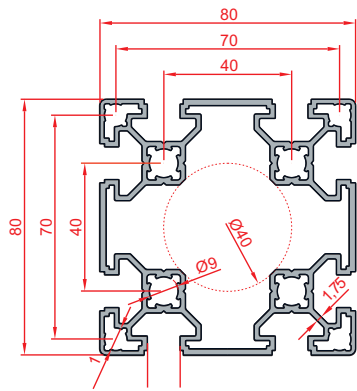
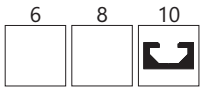

Stock Code	External Dimensions	Material	Moment of Inertia		Moments of Stength		Area	Mass
			$I_x$	$I_y$	$W_x$	$W_y$		
1.1.10.080080.02	80x80 Light (K10)	6063	88.05cm <sup>4</sup>	88.05cm <sup>4</sup>	22.01cm <sup>3</sup>	22.01cm <sup>3</sup>	11.91cm <sup>2</sup>	3.23 Kg/m

Standard : 6010 mm Lmax : 7200 mm

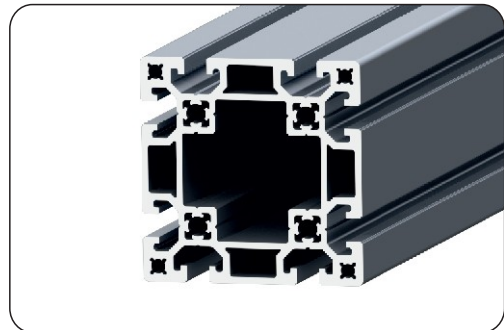
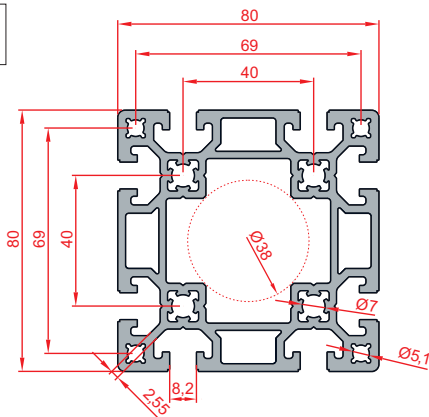

Stock Code	External Dimensions	Material	Moment of Inertia		Moments of Stength		Area	Mass
			$I_x$	$I_y$	$W_x$	$W_y$		
1.1.08.080080.01	80x80 (K8) Heavy	6063	143.34cm <sup>4</sup>	143.34cm <sup>4</sup>	35.84cm <sup>3</sup>	35.84cm <sup>3</sup>	19.87cm <sup>2</sup>	5.39 Kg/m

Standard : 6010 mm Lmax : 7200 mm

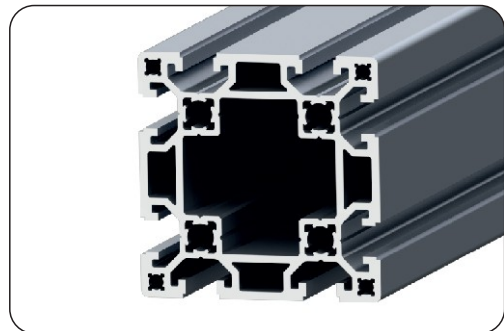
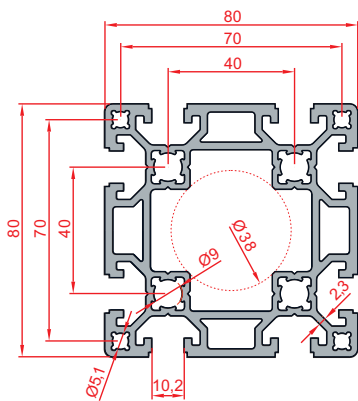
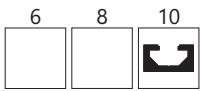

Stock Code	External Dimensions	Material	Moment of Inertia		Moments of Stength		Area	Mass
			$I_x$	$I_y$	$W_x$	$W_y$		
1.1.10.080080.01	80x80 Heavy (K10)	6063	127.00cm <sup>4</sup>	127.00cm <sup>4</sup>	31.75cm <sup>3</sup>	31.75cm <sup>3</sup>	17.76cm <sup>2</sup>	4.81 Kg/m

Standard : 6010 mm Lmax : 7200 mm

**Using Area**

**Light Series;** Can be used on poles of compartments with larger size, ceiling dressing frames and also as spot-bearing beams. These series of thin wall structure in wide category are preferred in areas without high loads.

**Heavy Series;** These profile series can meet required resistance at middle loading capacities and are preferred on bench bodies, machine frames and bearing platform beams.

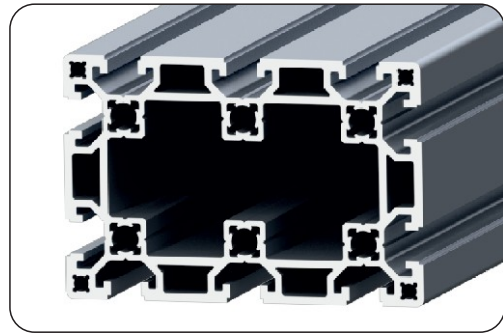
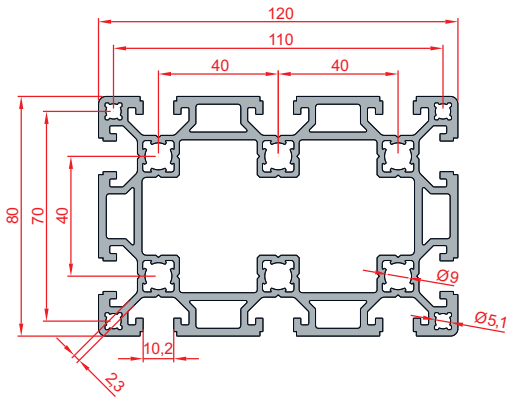
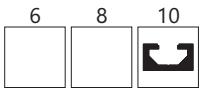

**80x120 Industrial Heavy Profile**

Code: 1.1.10.080120.01

Suitable for use in machine frames and bedding bodies requiring high strength. Triple slot provides wide bedding surface and strong connection.

Stock Code	External Dimensions	Material	Moment of Inertia		Moments of Strength		Area	Mass
			I <sub>x</sub>	I <sub>y</sub>	W <sub>x</sub>	W <sub>y</sub>		
1.1.10.080120.01	80x120 Heavy	6063	185.31cm <sup>4</sup>	379.59cm <sup>4</sup>	46.33cm <sup>3</sup>	63.26cm <sup>3</sup>	24.33cm <sup>2</sup>	6.59 Kg/m

Standard : 6010 mm Lmax : 7200 mm

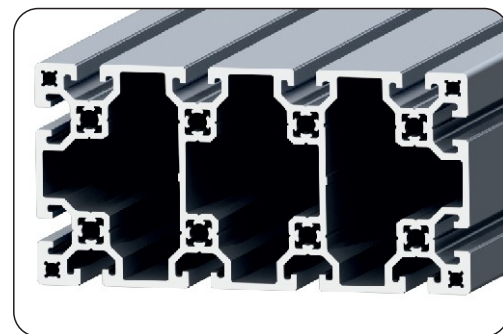
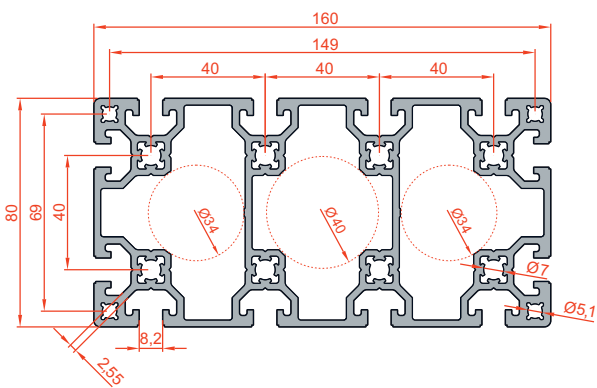

**80x160 (K8) Industrial Light Profile**

Code: 1.1.08.080160.02

Preferred on proslotion lines, machine frame formations and proslotion of strength-requiring constructions.

Stock Code	External Dimensions	Material	Moment of Inertia		Moments of Strength		Area	Mass
			I <sub>x</sub>	I <sub>y</sub>	W <sub>x</sub>	W <sub>y</sub>		
1.1.08.080160.02	80x160 Light	6063	242.27cm <sup>4</sup>	843.82cm <sup>4</sup>	60.57cm <sup>3</sup>	105.48cm <sup>3</sup>	30.56cm <sup>2</sup>	8.28 Kg/m

Standard : 6010 mm Lmax : 7200 mm

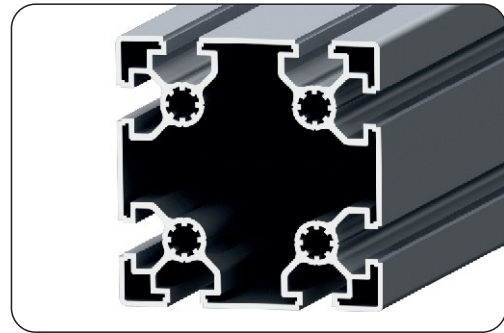
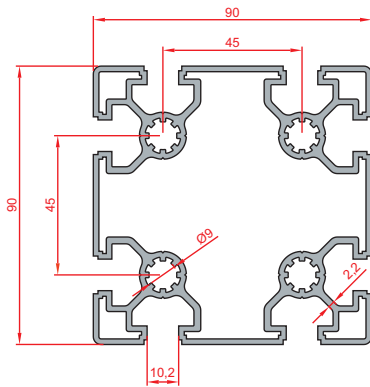
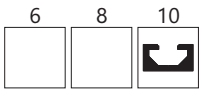

**90x90 Industrial Super Light Profile**

Code: 1.1.10.090090.04

Thanks to super-thin wall structure, it is preferred on frames not subject to load and on closing cabins of machines.

Stock Code	External Dimensions	Material	Moment of Inertia		Moments of Stength		Area	Mass
			I <sub>x</sub>	I <sub>y</sub>	W <sub>x</sub>	W <sub>y</sub>		
1.1.10.090090.04	90x90 Super Light	6063	143.13cm <sup>4</sup>	143.13cm <sup>4</sup>	31.81cm <sup>3</sup>	31.81cm <sup>3</sup>	15.20cm <sup>2</sup>	4.12 Kg/m

Standard : 6010 mm Lmax : 7200 mm

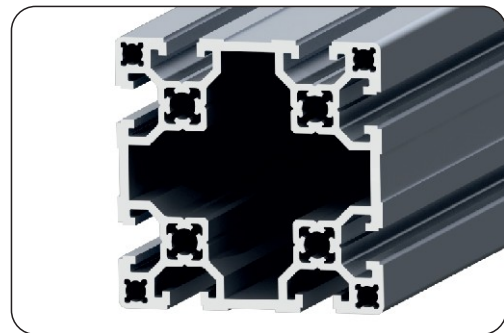
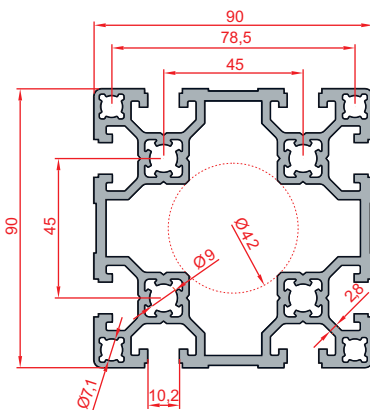

**90x90 Light Industrial Profile**

Code: 1.1.10.090090.02

A proslot that stands out with ideal structure in design of systems requiring medium-level resistance.Can be used on CNC machine feet and formation of wide-size frame applications.

Stock Code	External Dimensions	Material	Moment of Inertia		Moments of Stength		Area	Mass
			I <sub>x</sub>	I <sub>y</sub>	W <sub>x</sub>	W <sub>y</sub>		
1.1.10.090090.02	90x90 Light	6063	192.79cm <sup>4</sup>	192.79cm <sup>4</sup>	42.84cm <sup>3</sup>	42.84cm <sup>3</sup>	20.67cm <sup>2</sup>	5.60 Kg/m

Standard : 6010 mm Lmax : 7200 mm

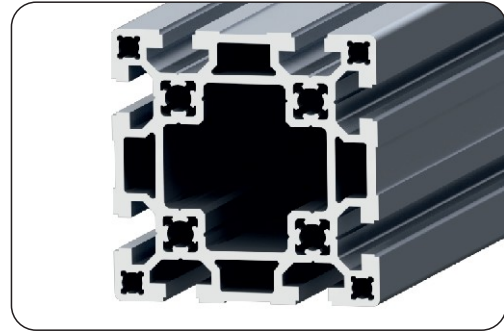
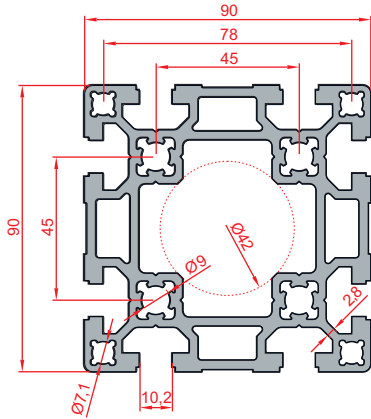
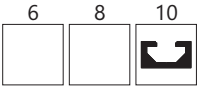

**90x90 Industrial Heavy Profile**

Code: 1.1.10.090090.01

Used as bearing profile on machine frames requiring high resistance, as as of larger constructions. By means of possible integration of mechanic proslots, it can also be used as frame for bearing axis.

Stock Code	External Dimensions	Material	Moment of Inertia		Moments of Stength		Area	Mass
			I <sub>x</sub>	I <sub>y</sub>	W <sub>x</sub>	W <sub>y</sub>		
1.1.10.090090.01	90x90 Heavy	6063	220.54cm <sup>4</sup>	220.54cm <sup>4</sup>	49.01cm <sup>3</sup>	49.01cm <sup>3</sup>	25.31cm <sup>2</sup>	6.86 Kg/m

Standard : 6010 mm Lmax : 7200 mm

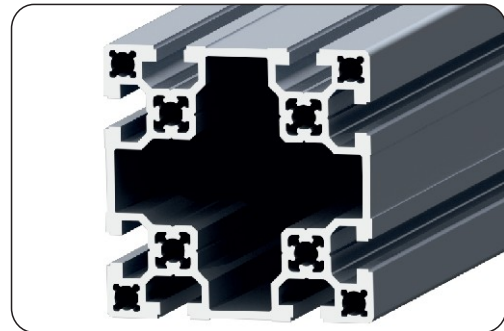
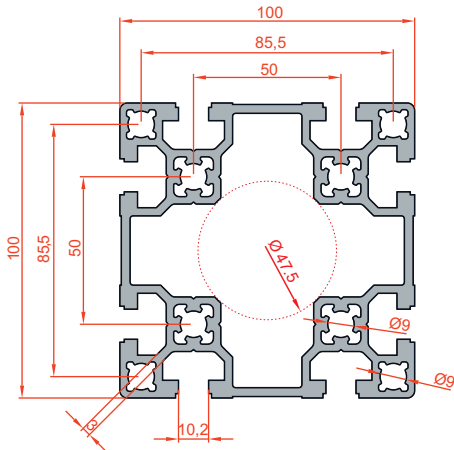
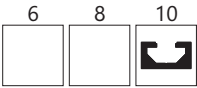

**100x100 Light Industrial Profile**

Code: 1.1.10.100100.02

A proslot that stands out with ideal structure in design of systems requiring medium-level resistance. Can be used on CNC machine feet and formation of wide-size frame applications.

Stock Code	External Dimensions	Material	Moment of Inertia		Moments of Stength		Area	Mass
			I <sub>x</sub>	I <sub>y</sub>	W <sub>x</sub>	W <sub>y</sub>		
1.1.10.100100.02	100x100 Light	6063	295.46cm <sup>4</sup>	295.46cm <sup>4</sup>	59.01m <sup>3</sup>	59.01cm <sup>3</sup>	25.51cm <sup>2</sup>	6.91 Kg/m

Standard : 6010 mm Lmax : 7200 mm



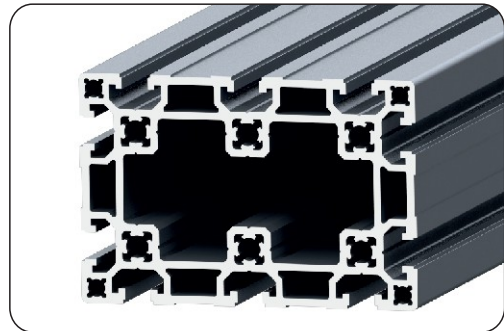
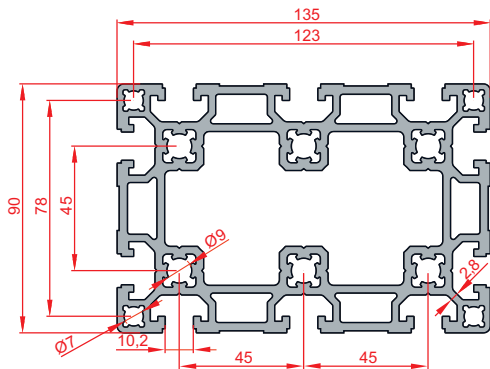
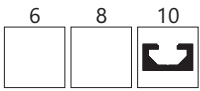

**90x135 Industrial Heavy Profile**

Code: 1.1.10.090135.01

Suitable for use in machine frames and bedding bodies requiring high strength. Triple slot provides wide bedding surface and strong connection.

Stock Code	External Dimensions	Material	Moment of Inertia		Moments of Stength		Area	Mass
			$I_x$	$I_y$	$W_x$	$W_y$		
1.1.10.090135.01	90x135 Heavy	6063	313.64cm <sup>4</sup>	652.97cm <sup>4</sup>	69.70cm <sup>3</sup>	96.74cm <sup>3</sup>	34.42cm <sup>2</sup>	9.33 Kg/m

Standard : 6010 mm Lmax : 7200 mm

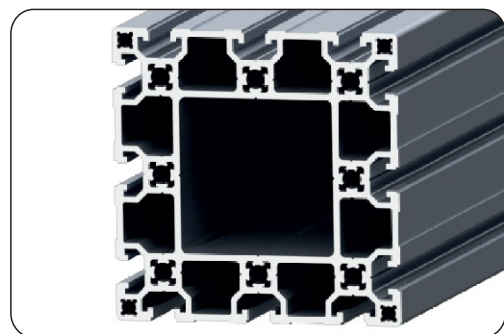
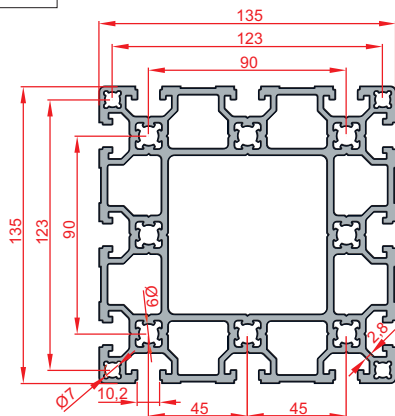
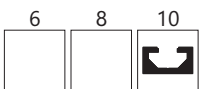

**135x135 Industrial Heavy Profile**

Code: 1.1.10.135135.01

Area of Use: Used in machine and frame constructions requiring high strength in order to obtain strong connections. Bedding connection can be made via assembly of linear guideways of 90 degrees from two surfaces on formation of machine coordinate axes.

Stock Code	External Dimensions	Material	Moment of Inertia		Moments of Stength		Area	Mass
			$I_x$	$I_y$	$W_x$	$W_y$		
1.1.10.135135.01	135x135 Heavy	6063	897.65cm <sup>4</sup>	897.65cm <sup>4</sup>	132.99cm <sup>3</sup>	132.99cm <sup>3</sup>	44.52cm <sup>2</sup>	12.06 Kg/m

Standard : 6010 mm Lmax : 7200 mm

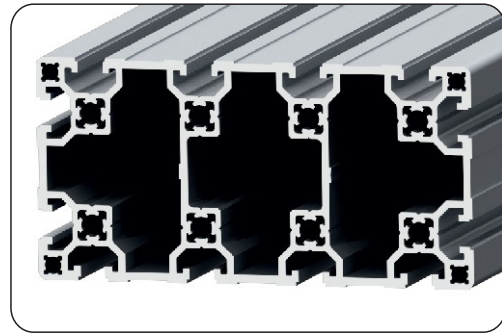
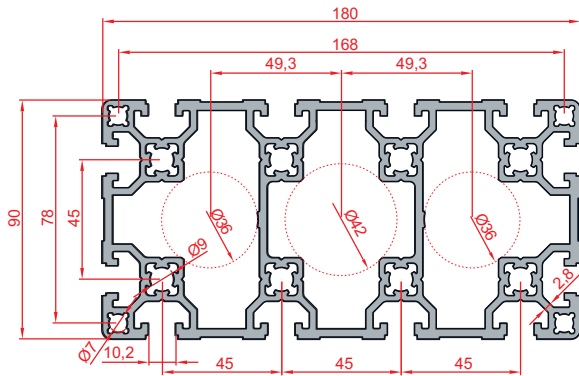
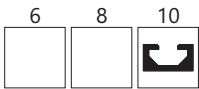

**90x180 Industrial Light Profile**

Code: 1.1.10.090180.02

Preferred in formation of proslotion lines and long-size constructions. Thanks to triple slot feature, it can also be employed as bearing profile.

Stock Code	External Dimensions	Material	Moment of Inertia		Moments of Stength		Area	Mass
			$I_x$	$I_y$	$W_x$	$W_y$		
1.1.10.090180.02	90x180 Light	6063	361.32cm <sup>4</sup>	1240.04cm <sup>4</sup>	80.29cm <sup>3</sup>	137.79cm <sup>3</sup>	37.06cm <sup>2</sup>	10.04 Kg/m

Standard : 6010 mm Lmax : 7200 mm

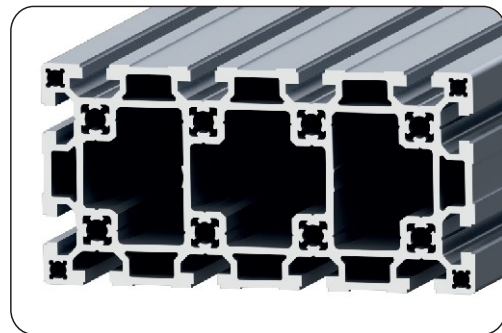
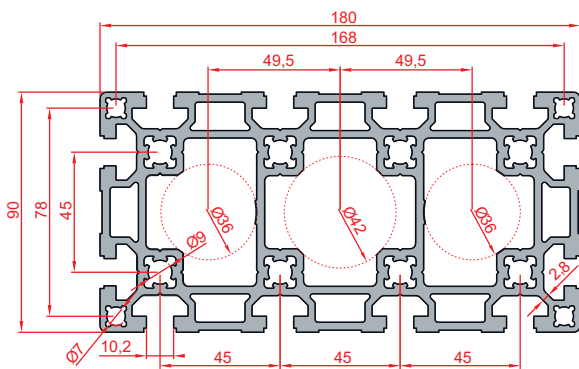
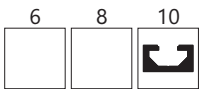

**90x180 Industrial Heavy Profile**

Code: 1.1.10.090180.01

Used as bearing profile on machine frames requiring high resistance, as as of larger constructions. By means of possible integration of mechanic proslots, it can also be used as frame for bearing axis.

Stock Code	External Dimensions	Material	Moment of Inertia		Moments of Stength		Area	Mass
			$I_x$	$I_y$	$W_x$	$W_y$		
1.1.10.090180.01	90x180 Heavy	6063	428.25cm <sup>4</sup>	1504.50cm <sup>4</sup>	95.17cm <sup>3</sup>	167.17cm <sup>3</sup>	46.82cm <sup>2</sup>	12.69 Kg/m

Standard : 6010 mm Lmax : 7200 mm

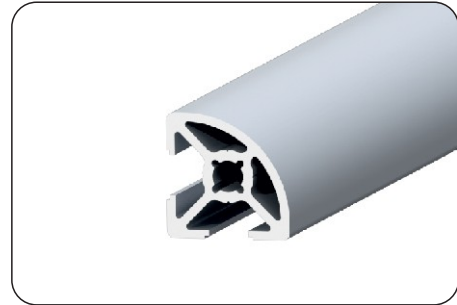
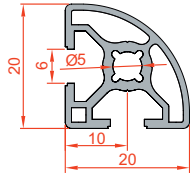
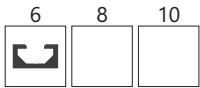

Stock Code	External Dimensions	Material	Moment of Inertia		Moments of Strength		Area	Mass
			$I_x$	$I_y$	$W_x$	$W_y$		
1.1.06.020020.08	20x20 Radius	6063	$0.52\text{cm}^4$	$0.52\text{cm}^4$	$0.50\text{cm}^3$	$0.50\text{cm}^3$	$1.42\text{cm}^2$	0.39 Kg/m

Standard : 6010 mm Lmax : 7200 mm

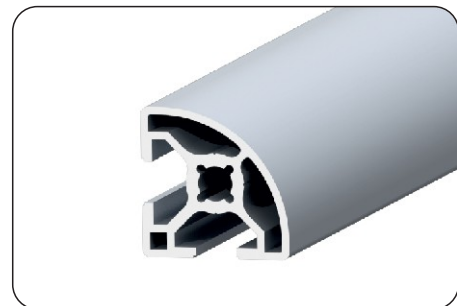
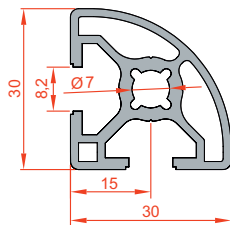

Stock Code	External Dimensions	Material	Moment of Inertia		Moments of Strength		Area	Mass
			$I_x$	$I_y$	$W_x$	$W_y$		
1.1.08.030030.08	30x30 Radius	6063	$2.17\text{cm}^4$	$2.17\text{cm}^4$	$1.32\text{cm}^3$	$1.32\text{cm}^3$	$2.78\text{cm}^2$	0.75 Kg/m

Standard : 6010 mm Lmax : 7200 mm

### Using Area

This profile is used in where decorative appearance is preferred such as designs of stands, panels, and cabins. An aesthetic appearance is obtained by applications of special connectors and accessories.

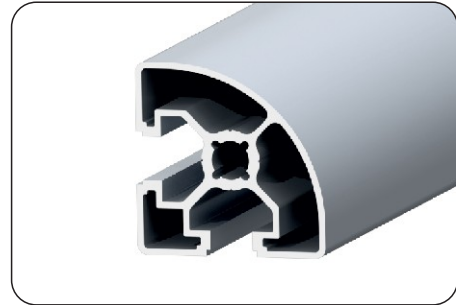
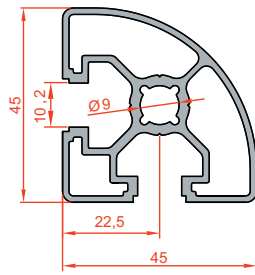
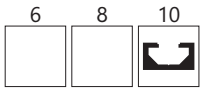

Stock Code	External Dimensions	Material	Moment of Inertia		Moments of Stength		Area	Mass
			$I_x$	$I_y$	$W_x$	$W_y$		
1.1.10.045045.08	45x45 Radius	6063	$7.77\text{cm}^4$	$7.77\text{cm}^4$	$3.10\text{cm}^3$	$3.10\text{cm}^3$	$4.46\text{cm}^2$	1.21 Kg/m

Standard : 6010 mm Lmax : 7200 mm

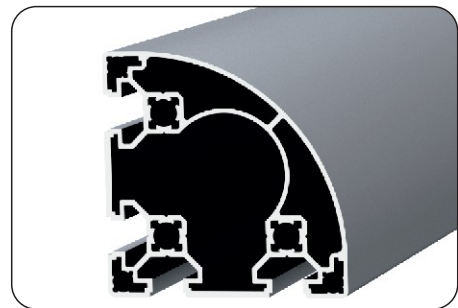
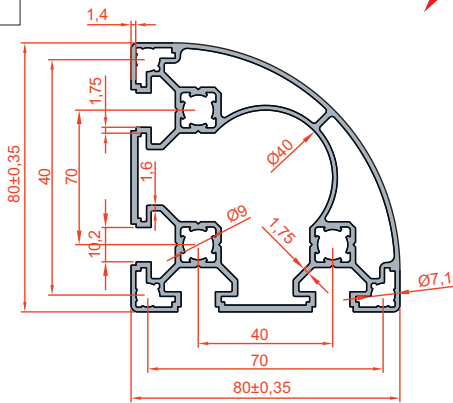

Stock Code	External Dimensions	Material	Moment of Inertia		Moments of Stength		Area	Mass
			$I_x$	$I_y$	$W_x$	$W_y$		
1.1.10.080080.08	80x80 Radius	6063	$66.41\text{cm}^4$	$66.41\text{cm}^4$	$14.59\text{cm}^3$	$14.59\text{cm}^3$	$10.23\text{cm}^2$	2.77 Kg/m

Standard : 6010 mm Lmax : 7200 mm

### Using Area

This profile is used in where decorative appearance is preferred such as designs of stands, panels, and cabins. An aesthetic appearance is obtained by applications of special connectors and accessories.

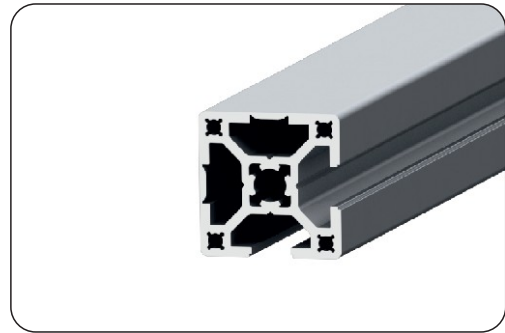
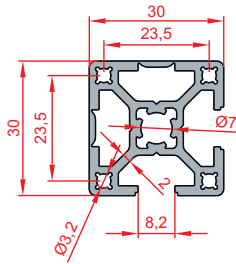

Stock Code	External Dimensions	Material	Moment of Inertia		Moments of Stength		Area	Mass
			$I_x$	$I_y$	$W_x$	$W_y$		
1.1.08.030030.05	30x30 Closed	6063	$3.18\text{cm}^4$	$3.18\text{cm}^4$	$2.06\text{cm}^3$	$2.06\text{cm}^3$	$3.38\text{cm}^2$	0.92 Kg/m

Standard : 6010 mm Lmax : 7200 mm

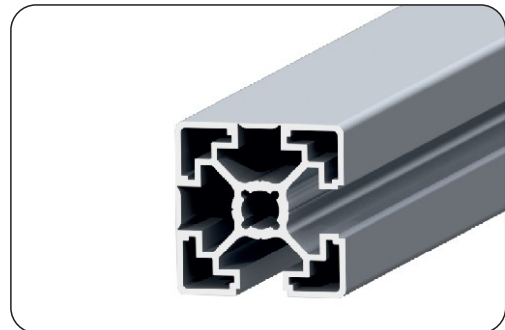
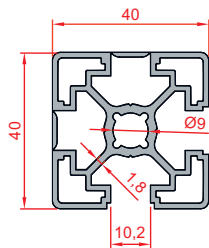

Stock Code	External Dimensions	Material	Moment of Inertia		Moments of Stength		Area	Mass
			$I_x$	$I_y$	$W_x$	$W_y$		
1.1.10.040040.05	40x40 Closed	6063	$7.28\text{cm}^4$	$7.28\text{cm}^4$	$3.53\text{cm}^3$	$3.53\text{cm}^3$	$4.63\text{cm}^2$	1.25 Kg/m

Standard : 6010 mm Lmax : 7200 mm

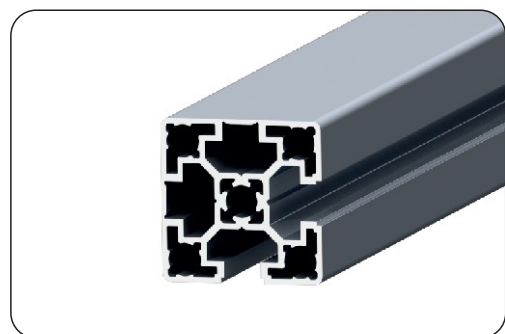
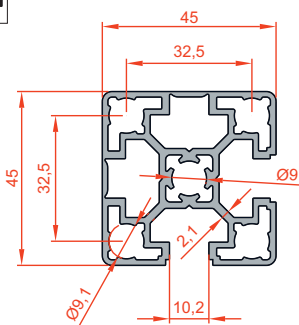

Stock Code	External Dimensions	Material	Moment of Inertia		Moments of Stength		Area	Mass
			$I_x$	$I_y$	$W_x$	$W_y$		
1.1.10.045045.05	45x45 Closed	6063	$11.83\text{cm}^4$	$11.83\text{cm}^4$	$5.13\text{cm}^3$	$5.13\text{cm}^3$	$5.93\text{cm}^2$	1.61 Kg/m

Standard : 6010 mm Lmax : 7200 mm

### Using Area

Its closed exterior surface provides hygiene and aesthetic appearance Preferable to use on building of filling machines, medicine production lines, packing units etc. Closed canals can be opened for the accessories to be place in.

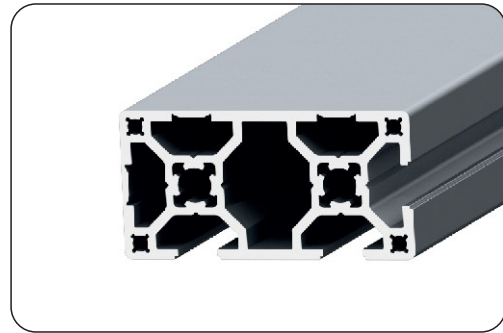
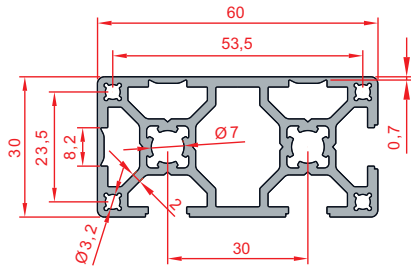
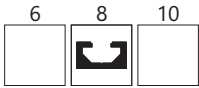

Stock Code	External Dimensions	Material	Moment of Inertia		Moments of Stength		Area	Mass
			$I_x$	$I_y$	$W_x$	$W_y$		
1.1.08.030060.05	30X60 Closed	6063	$5.90\text{cm}^4$	$21.55\text{cm}^4$	$3.80\text{cm}^3$	$7.06\text{cm}^3$	$5.92\text{cm}^2$	1.60 Kg/m

Standard : 6010 mm Lmax : 7200 mm

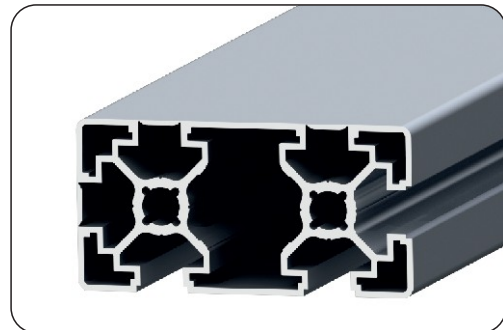
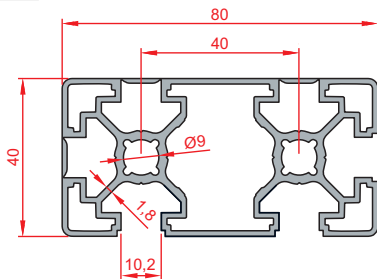

Stock Code	External Dimensions	Material	Moment of Inertia		Moments of Stength		Area	Mass
			$I_x$	$I_y$	$W_x$	$W_y$		
1.1.10.040080.05	40x80 Closed	6063	$12.84\text{cm}^4$	$50.93\text{cm}^4$	$6.22\text{cm}^3$	$12.56\text{cm}^3$	$7.69\text{cm}^2$	2.08 Kg/m

Standard : 6010 mm Lmax : 7200 mm

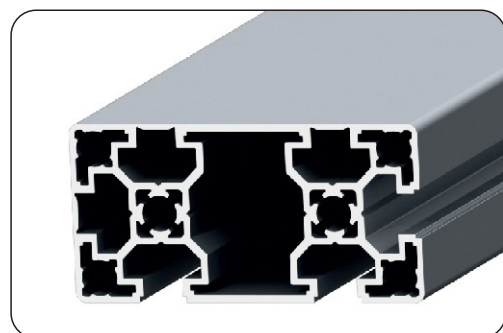
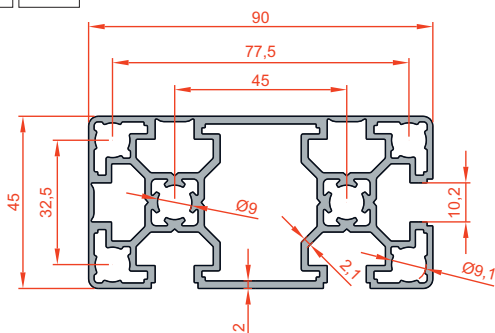

Stock Code	External Dimensions	Material	Moment of Inertia		Moments of Stength		Area	Mass
			$I_x$	$I_y$	$W_x$	$W_y$		
1.1.10.045090.05	45x90 Closed	6063	$22.22\text{cm}^4$	$83.70\text{cm}^4$	$9.59\text{cm}^3$	$18.32\text{cm}^3$	$10.11\text{cm}^2$	2.74 Kg/m

Standard : 6010 mm Lmax : 7200 mm

Using Area

Since outer surface slots are closed, it ensures hygiene and stylish view. Used on filling machines, pharmaceutical proslotion lines and packaging plants. Closed slots can be torn for any required connection or accessory.

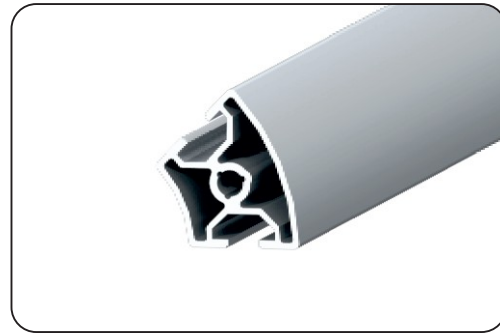
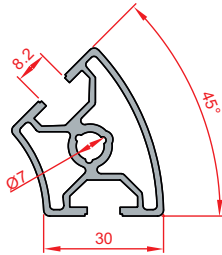
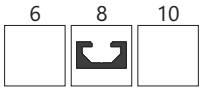

Stock Code	External Dimensions	Material	Moment of Inertia		Moments of Stength		Area	Mass
			$I_x$	$I_y$	$W_x$	$W_y$		
1.1.08.030045.08	30x45 Angled	6063	4.37cm <sup>4</sup>	3.22cm <sup>4</sup>	1.78cm <sup>3</sup>	1.62cm <sup>3</sup>	3.36cm <sup>2</sup>	0.91 Kg/m

Standard : 6010 mm Lmax : 7200 mm

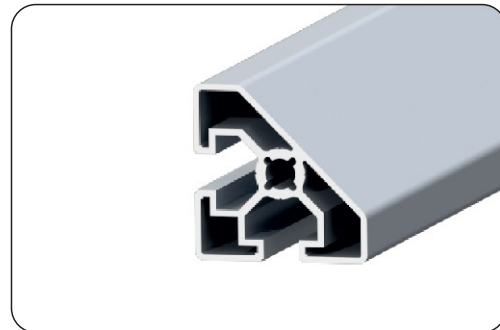
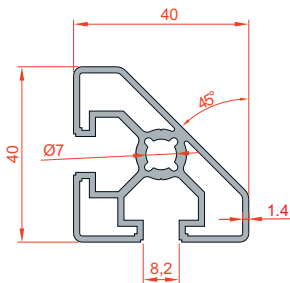

Stock Code	External Dimensions	Material	Moment of Inertia		Moments of Stength		Area	Mass
			$I_x$	$I_y$	$W_x$	$W_y$		
1.1.08.040040.06	40x40 (45°)	6063	4.48cm <sup>4</sup>	4.48cm <sup>4</sup>	1.94cm <sup>3</sup>	1.94cm <sup>3</sup>	3.44cm <sup>2</sup>	0.93 Kg/m

Standard : 6010 mm Lmax : 7200 mm

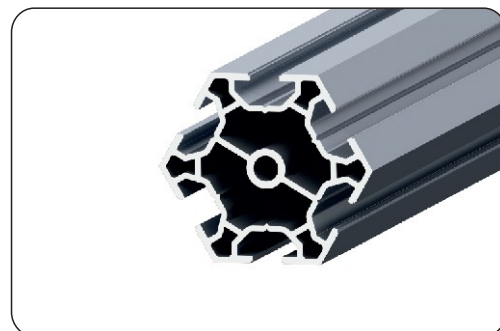
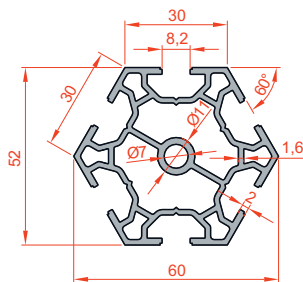

Stock Code	External Dimensions	Material	Moment of Inertia		Moments of Stength		Area	Mass
			$I_x$	$I_y$	$W_x$	$W_y$		
1.1.08.030030.06	Hexagonal K8 Stand Profile of 30	6063	14.69cm <sup>4</sup>	14.88cm <sup>4</sup>	5.66cm <sup>3</sup>	4.96cm <sup>3</sup>	6.38cm <sup>2</sup>	1.73 Kg/m

Standard : 6010 mm Lmax : 7200 mm

**Using Area**

**30x45 Angled Profile;** The 45° angle enables easy integration. Stylish view ensures elegance in machine cabins and desk corners.

**40x40 45° Angular Profile;** Ensures a different view of 45° in outer surfaces of machine cabins and booths. Comprises specific fasteners and accessories.

**Hexagonal K8 Stand Profile Of 30;** These series are used in stand operations, decorative table feet etc. Stylish view can be ensured through various surface-covering options.

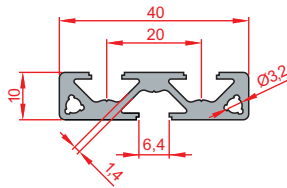
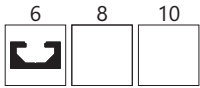

**10x40 Surface Coating Profile**

Code: 11.1.06.010040.07

A profile designed for small-size requirements within surface coating profiles. In applications within limited space, it is possible to provide required options and to create units where smaller system elements can be easily attached.

Stock Code	External Dimensions	Material	Moment of Inertia		Moments of Stength		Area	Mass
			$I_x$	$I_y$	$W_x$	$W_y$		
1.1.06.010040.07	10x40 Surface Coating Profile	6063	$0.20\text{cm}^4$	$3.37\text{cm}^4$	$0.38\text{cm}^3$	$1.68\text{cm}^3$	$2.04\text{cm}^2$	0.55 Kg/m

Standard : 6010 mm

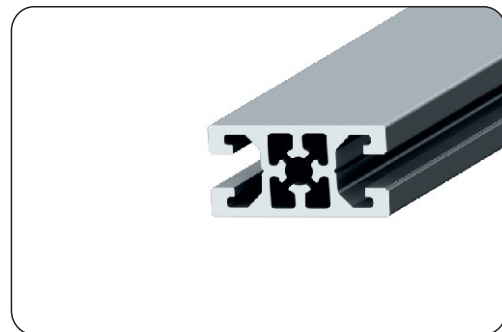
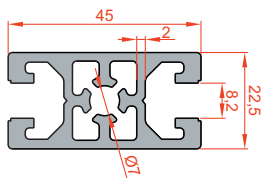
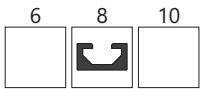

**22,5x45 Panel Profile**

Code: 1.1.08.225045.01

New series of sigma profile developed for panel compartments, ensuring decorative look.

Stock Code	External Dimensions	Material	Moment of Inertia		Moments of Stength		Area	Mass
			$I_x$	$I_y$	$W_x$	$W_y$		
1.1.08.225045.01	22,5x45 Panel Profile	6063	$2.95\text{cm}^4$	$8.15\text{cm}^4$	$2.63\text{cm}^3$	$3.62\text{cm}^3$	$4.63\text{cm}^2$	1.25 Kg/m

Standard : 6010 mm



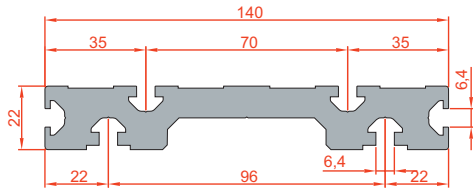
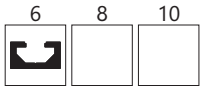

**22x140 Surface Coating Profile**

Code: 1.1.06.022140.07

Can be used in formation of machine tables subject to load and also as Z-axis bearing profile. Strong wall structure enables solid connection of mechanic and pneumatic parts.

Stock Code	External Dimensions	Material	Moment of Inertia		Moments of Stength		Area	Mass
			$I_x$	$I_y$	$W_x$	$W_y$		
1.1.06.022140.07	22x140	6063	$7.30\text{cm}^4$	$365.46\text{cm}^4$	$5.81\text{cm}^3$	$52.21\text{cm}^3$	$19.85\text{cm}^2$	5.38 Kg/m

Standard : 6010 mm Lmax : 7200 mm

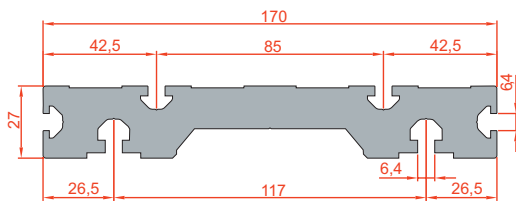

**27x170 Surface Coating Profile**

Code: 1.1.06.027170.07

A stronger plating profile with wider surface than other series. Used on upper and side surface plating etc. of heavy-duty machine tables. Ensures reliable connection of mechanic and pneumatic parts thanks to strong wall structure.

Stock Code	External Dimensions	Material	Moment of Inertia		Moments of Stength		Area	Mass
			$I_x$	$I_y$	$W_x$	$W_y$		
1.1.06.027170.07	27x170	6063	$16.86\text{cm}^4$	$852.78\text{cm}^4$	$10.98\text{cm}^3$	$100.33\text{cm}^3$	$32.44\text{cm}^2$	8.79 Kg/m

Standard : 6010 mm Lmax : 7200 mm

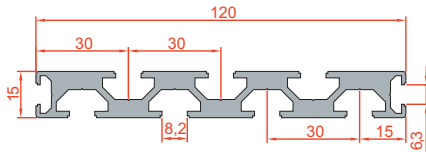
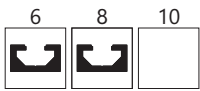

**15x120 Surface Coating Profile**

Code: 1.1.08.015120.07

This kind of profile is preferred on coverings of surfaces that are not subject to load. Areas of use include mini CNC tables, test and assembly benches etc.

Stock Code	External Dimensions	Material	Moment of Inertia		Moments of Stength		Area	Mass
			$I_x$	$I_y$	$W_x$	$W_y$		
1.1.08.015120.07	15x120	6063	$2.11\text{cm}^4$	$105.77\text{cm}^4$	$2.67\text{cm}^3$	$17.63\text{cm}^3$	$8.61\text{cm}^2$	2.33 Kg/m

Standard : 5500 mm Lmax : 7200 mm

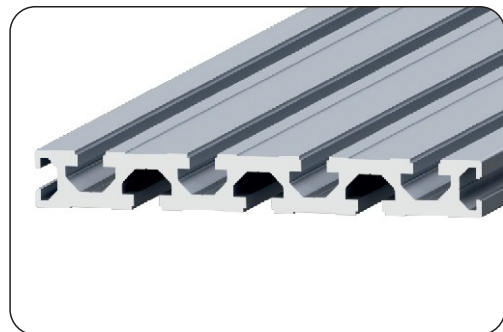
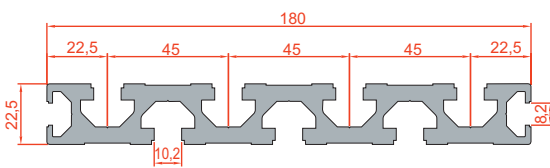

**22,5x180 Surface Coating Profile**

Code: 1.1.10.225180.07

Profile designed for ensuring strong surfaces on machine bodies of larger size that are subject to loads. Strong wall structure and surface slots allow reliable assembly of functional fasteners.

Stock Code	External Dimensions	Material	Moment of Inertia		Moments of Stength		Area	Mass
			$I_x$	$I_y$	$W_x$	$W_y$		
1.1.10.225180.07	22,5x180	6063	$11.69\text{cm}^4$	$570.85\text{cm}^4$	$10.14\text{cm}^3$	$63.43\text{cm}^3$	$21.13\text{cm}^2$	5.73 Kg/m

Standard : 6010 mm Lmax : 7200 mm

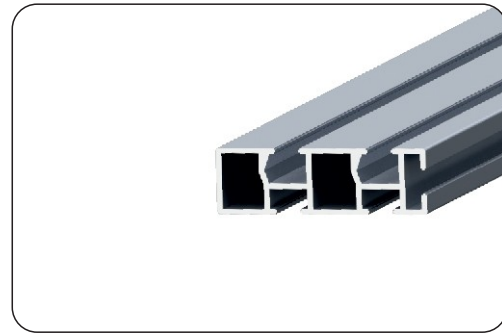
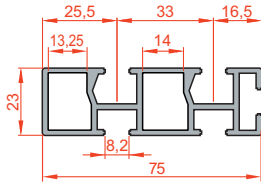

**23x75 Conveyor Profile**

Code: 1.2.00.023075.00

Main body in the production of belt and roller conveyor systems are used in their formation. Easy to integrate Practical assembly with connection equipment and accessories opportunity is provided.

Stock Code	External Dimensions	Material	Moment of Inertia		Moments of Stength		Area	Mass
			$I_x$	$I_y$	$W_x$	$W_y$		
1.2.00.023075.00	23x75 Conveyor Profile	6063	$3.11\text{cm}^4$	$26.02\text{cm}^4$	$2.70\text{cm}^3$	$6.94\text{cm}^3$	$4.85\text{cm}^2$	1.32 Kg/m

Standard : 6010 mm Lmax : 7200 mm

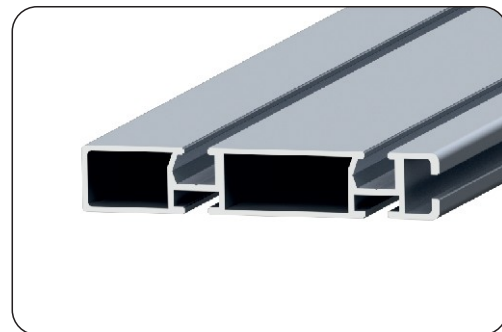
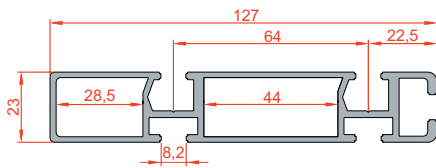

**23x127 Conveyor Profile**

Code: 1.2.00.023127.00

Preferred as side frame profile on middle-loading conveyors with belt or roller. Ensures assembly in coherence with specific tension and driven plates.

Stock Code	External Dimensions	Material	Moment of Inertia		Moments of Stength		Area	Mass
			$I_x$	$I_y$	$W_x$	$W_y$		
1.2.00.023127.00	23x127 Conveyor Profile	6063	$5.46\text{cm}^4$	$113.07\text{cm}^4$	$4.71\text{cm}^3$	$17.23\text{cm}^3$	$7.38\text{cm}^2$	2.01 Kg/m

Standard : 6010 mm Lmax : 7200 mm

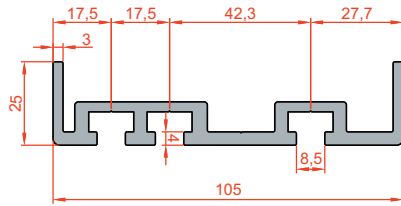
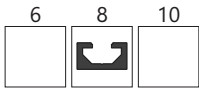

Stock Code	External Dimensions	Material	Moment of Inertia		Moments of Strength		Area	Mass
			$I_x$	$I_y$	$W_x$	$W_y$		
1.2.00.025105.00	25x105 Conveyor Profile	6063	$2.40\text{cm}^4$	$86.71\text{cm}^4$	$1.35\text{cm}^3$	$16.01\text{cm}^3$	$7.42\text{cm}^2$	2.01 Kg/m

Standard : 6010 mm Lmax : 7200 mm

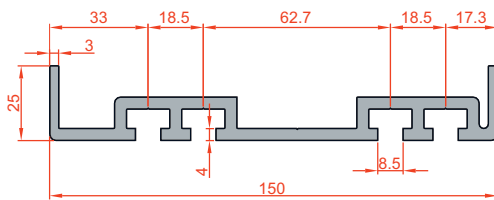

Stock Code	External Dimensions	Material	Moment of Inertia		Moments of Strength		Area	Mass
			$I_x$	$I_y$	$W_x$	$W_y$		
1.2.00.025150.00	25x150 Conveyor Profile	6063	$3.45\text{cm}^4$	$244.90\text{cm}^4$	$1.97\text{cm}^3$	$31.57\text{cm}^3$	$10.72\text{cm}^2$	2.90 Kg/m

Standard : 6010 mm Lmax : 7200 mm

Using Area

**25x105 & 25x150;** Profile series designed for formation of modular and acetal belt conveyor frames with large gear diameter. Can be easily mounted with compatible plates.

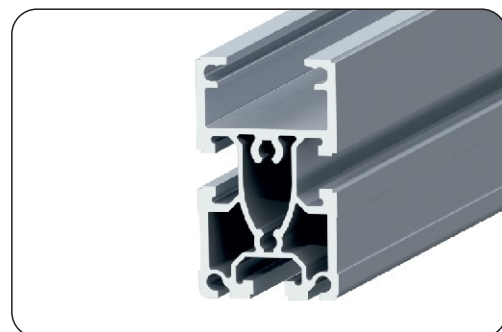
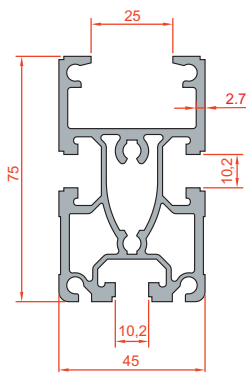

Using Area

Narrow-belt conveyor profile offers practical solutions in formation of conveyors for palletized transport. The friction plastic, mounted on upper slot of profile, provides a guide for moving belt.

Stock Code	External Dimensions	Material	Moment of Inertia		Moments of Strength		Area	Mass
			$I_x$	$I_y$	$W_x$	$W_y$		
1.2.00.045075.00	45x75 Conveyor Profile	6063	$23.46\text{cm}^4$	$45.80\text{cm}^4$	$10.50\text{cm}^3$	$11.17\text{cm}^3$	$9.42\text{cm}^2$	2.55 Kg/m

Standard : 6010 mm Lmax : 7200 mm

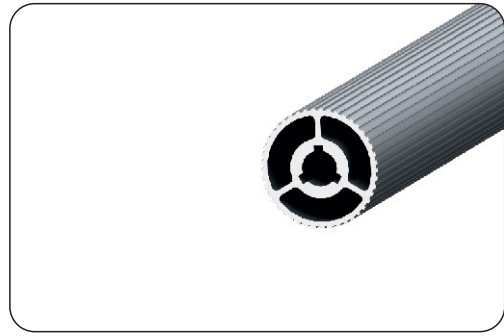
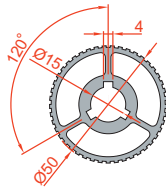

Stock Code	External Dimensions	Material	Moment of Inertia		Moments of Stength		Area	Mass
			$I_x$	$I_y$	$W_x$	$W_y$		
1.2.00.050.01	Drum Profile (Aluminum) Ø50	6063	12.44cm <sup>4</sup>	12.44cm <sup>4</sup>	4.98cm <sup>3</sup>	4.98cm <sup>3</sup>	7.13 cm <sup>2</sup>	1.93 Kg/m

Standard : 3200 mm

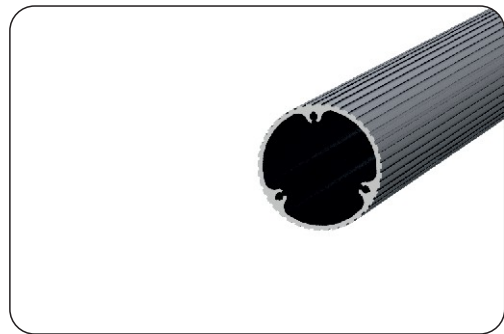
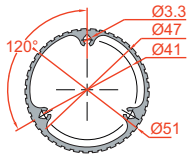

Stock Code	External Dimensions	Material	Moment of Inertia		Moments of Stength		Area	Mass
			$I_x$	$I_y$	$W_x$	$W_y$		
1.2.00.051.01	Drum Profile (Aluminum) Ø50	6063	10.16cm <sup>4</sup>	10.16cm <sup>4</sup>	3.99cm <sup>3</sup>	3.99cm <sup>3</sup>	3.58cm <sup>2</sup>	0.97 Kg/m

Standard : 3200 mm

**Using Area**

This profiles which used in forming of tension-drive drums, are the most important component of drive transmission in conveyor systems. The serrated form on the surfaces of the profiles is minimizes the sliding risk of the material, so it provides a linear flow of material even the lightest loads. Therewithal, the length options that can be produced according to the special sizes, allow the use of different width bands.

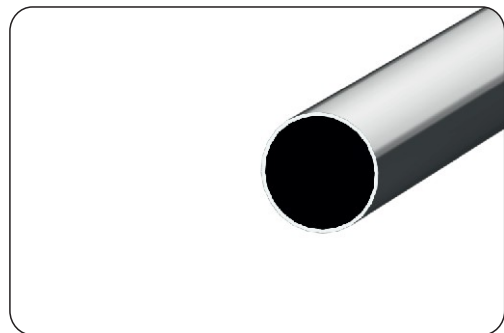
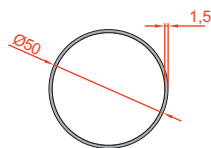

Stock Code	External Dimensions	Material	Moment of Inertia		Moments of Stength		Area	Mass
			$I_x$	$I_y$	$W_x$	$W_y$		
1.6.00.050014	Aluminum Tube Ø50*1.5 Polished	6063	6.73cm <sup>4</sup>	6.73cm <sup>4</sup>	2.70cm <sup>3</sup>	2.70cm <sup>3</sup>	2.29cm <sup>2</sup>	0.62 Kg/m
1.6.00.050014.01	Aluminum Tube Ø50*1.5 Matte	6063	6.73cm <sup>4</sup>	6.73cm <sup>4</sup>	2.70cm <sup>3</sup>	2.70cm <sup>3</sup>	2.29cm <sup>2</sup>	0.62Kg/m

Standard : 6010 mm

**Using Area**

Ø50x1,5 Aluminium pipes, roller, idler roll exc. they are used for manufacturing of the products . they are preferred for lightly loaded roller applications.

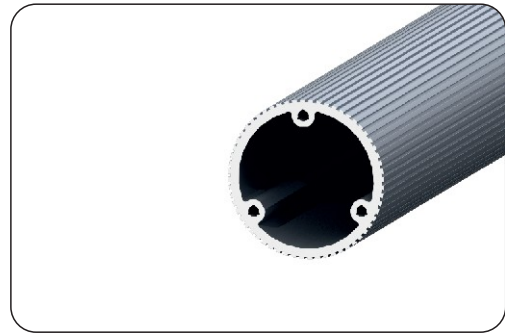
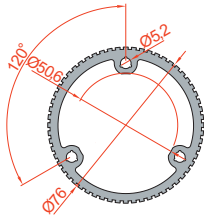

Stock Code	External Dimensions	Material	Moment of Inertia		Moments of Stength		Area	Mass
			$I_x$	$I_y$	$W_x$	$W_y$		
1.2.00.076.01	Drum Profile (Aluminum) Ø76	6063	70.10cm <sup>4</sup>	70.10cm <sup>4</sup>	18.48cm <sup>3</sup>	18.45cm <sup>3</sup>	11.70cm <sup>2</sup>	3.17 Kg/m

Standard : 3200 mm

**Using Area**

This profiles which used in forming of tension-drive drums, are the most important component of drive transmission in conveyor systems. The serrated form on the surfaces of the profiles is minimizes the sliding risk of the material, so it provides a linear flow of material even the lightest loads. Therewithal, the length options that can be produced according to the special sizes, allow the use of different width bands.

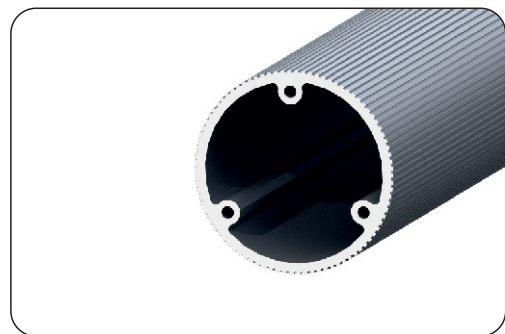
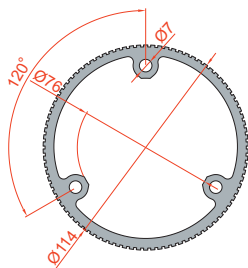

Stock Code	External Dimensions	Material	Moment of Inertia		Moments of Stength		Area	Mass
			$I_x$	$I_y$	$W_x$	$W_y$		
1.2.00.114.01	Drum Profile (Aluminum) Ø114	6063	311.15cm <sup>4</sup>	311.15cm <sup>4</sup>	54.59cm <sup>3</sup>	54.59cm <sup>3</sup>	22.52cm <sup>2</sup>	6.10 Kg/m

Standard : 3200 mm

**Using Area**

This profiles which used in forming of tension-drive drums, are the most important component of drive transmission in conveyor systems. The serrated form on the surfaces of the profiles is minimizes the sliding risk of the material, so it provides a linear flow of material even the lightest loads. Therewithal, the length options that can be produced according to the special sizes, allow the use of different width bands.

**Ø 12 Block Bearing Profile**

Code: 1.3.12.030082.00

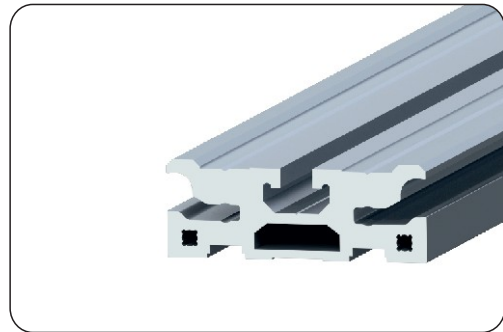
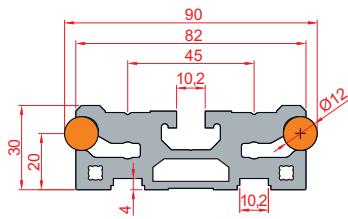

Stock Code	External Dimensions	Material	Moment of Inertia		Moments of Stength		Area	Mass
			$I_x$	$I_y$	$W_x$	$W_y$		
1.3.12.030082.00	Ø12 Block Bearing Profile	6063	$10.50\text{cm}^4$	$82.56\text{cm}^4$	$6.82\text{cm}^3$	$20.14\text{cm}^3$	$13.90\text{cm}^2$	3.77 Kg/m

**Ø 20 Block Bearing Profile**

Code: 1.3.20.040086.00

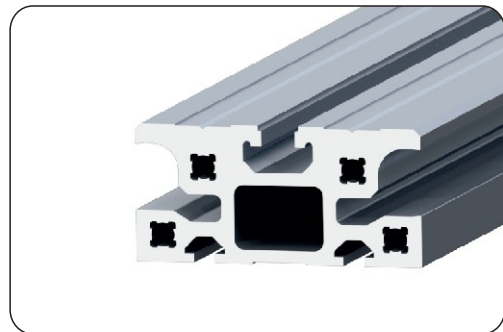
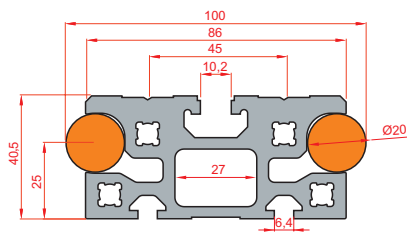

Stock Code	External Dimensions	Material	Moment of Inertia		Moments of Stength		Area	Mass
			$I_x$	$I_y$	$W_x$	$W_y$		
1.3.20.040086.00	Ø20 Block Bearing Profile	6063	$30.07\text{cm}^4$	$106.59\text{cm}^4$	$14.19\text{cm}^3$	$24.80\text{cm}^3$	$17.03\text{cm}^2$	4.61 Kg/m

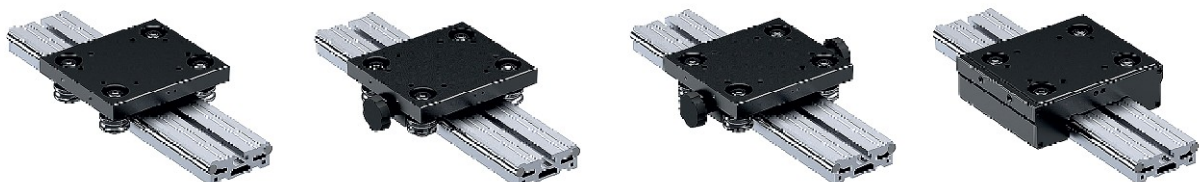

**Using Area**

The block bearing profiles are preferred for guidances that require middle-stage loading . It can be mounted on different cross-section sigma profiles to make strong bearing group.

**38x50 Bearing Profile**  
Code: 1.3.15.038050.0

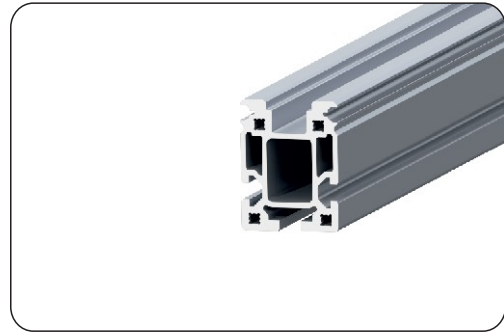
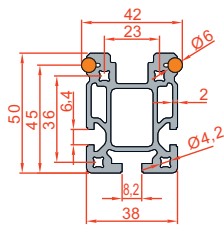

Stock Code	External Dimensions	Material	Moment of Inertia		Moments of Stength		Area	Mass
			$I_x$	$I_y$	$W_x$	$W_y$		
1.3.15.038050.00	38x50 Bearing Profile	6063	$18.53\text{cm}^4$	$11.68\text{cm}^4$	$7.16\text{cm}^3$	$6.15\text{cm}^3$	$7.14\text{cm}^2$	1.94 Kg/m

**60x80 Bearing Profile**  
Code: 1.3.15.060080.0

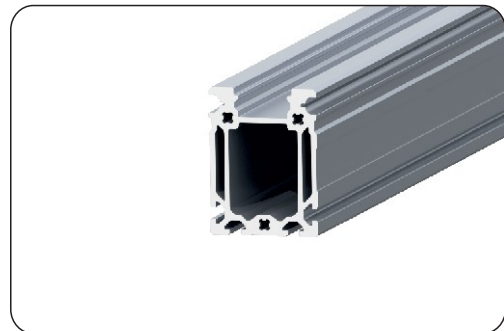
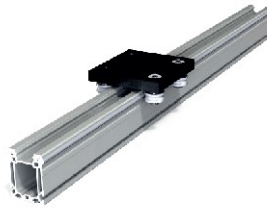
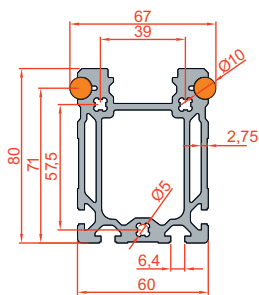

Stock Code	External Dimensions	Material	Moment of Inertia		Moments of Stength		Area	Mass
			$I_x$	$I_y$	$W_x$	$W_y$		
1.3.15.060080.00	60x80 Bearing Profile	6063	$108.90\text{cm}^4$	$68.22\text{cm}^4$	$26.59\text{cm}^3$	$22.74\text{cm}^3$	$15.23\text{cm}^2$	4.13 Kg/m

**80x80 Bearing Profile**  
Code: 1.3.0.15.080080.00

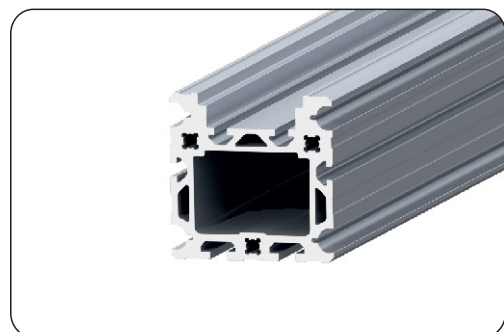
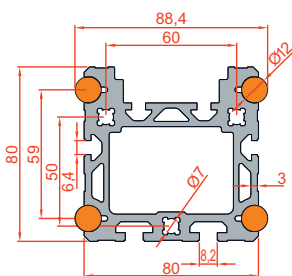

Stock Code	External Dimensions	Material	Moment of Inertia		Moments of Stength		Area	Mass
			$I_x$	$I_y$	$W_x$	$W_y$		
1.3.15.080080.00	80x80 Bearing Profile	6063	$135.35\text{cm}^4$	$161.00\text{cm}^4$	$33.16\text{cm}^3$	$40.25\text{cm}^3$	$21.04\text{cm}^2$	5.70 Kg/m

**Using Area**

The most important features of these bearing profiles can be coupled directly to the shafts without claw profile. Also , the nominal cross-section industrial profiles can be easily integrated.



**Ø 12 Bed Nail Profile**  
Code: 1.3.12.000000.00

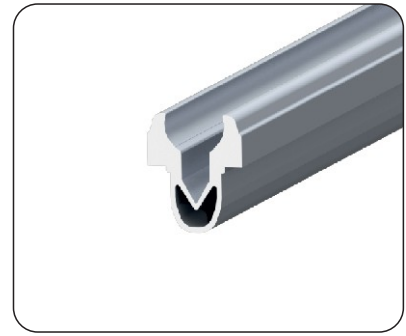
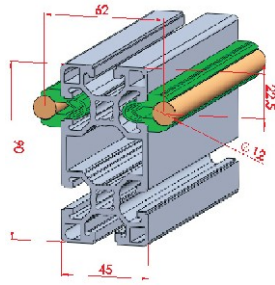

**Ø 20 Bed Nail Profile**  
Code: 1.3.20.000000.00

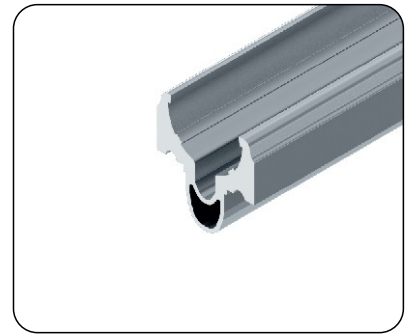
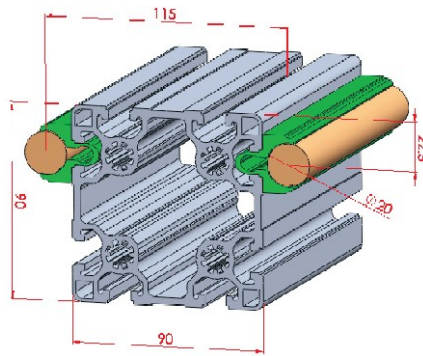

Code	Name of the product	Material	Mass
1.3.12.000000.00	Ø 12 Bed Nail Profile	Aluminum	1mt/0,41 Kg
1.3.20.000000.00	Ø 20 Bed Nail Profile	Aluminum	1mt/0,58 Kg

**Using Area**

Assembly of bedding shafts of Ø12 subject to light loads is ensured via tab profiles.. (above) Assembly of bedding shafts of Ø20 subject to medium loads is ensured via tab profiles. (below)

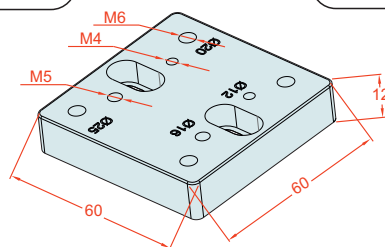
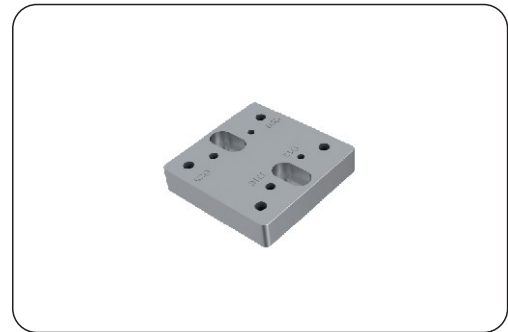
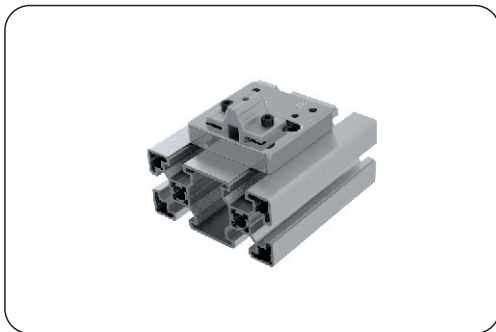

Code	Name of the product	Material	Weight
4.1.10.000000.0.00.0	Shaft Lower Support Connection Plate	Aluminum	113 gr

**Using Area**

Its used as connection device between sigma profiles and shaft support profiles



Shaft Lower Support Profile (Without Holes)

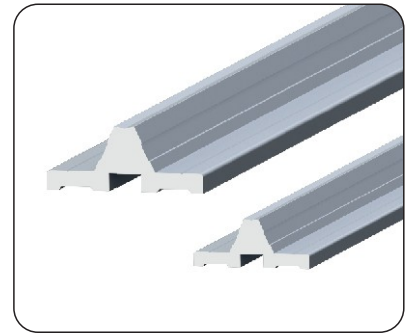
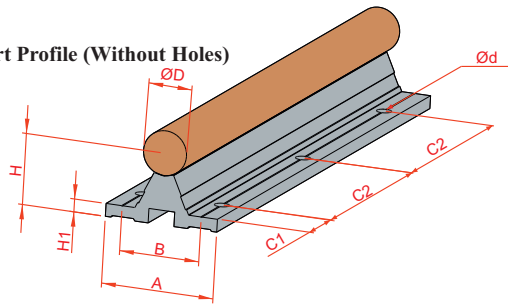

Lower Support Imperforate Profile (Code)	Name of the product	WEIGHT KG/M	DIMENSIONS (MM)				L MAX ; 6000 MM			
			A	H	H1	B	Ød	C1	C2	K DIN 6912
1.3.12.040016.00	Ø12 Lower Support Profile	0.69	40	22 <sup>+0.1</sup>	5	29	4.5	50	75	M4x16
1.3.16.045018.00	Ø16 Lower Support Profile	0.84	45	26 <sup>+0.1</sup>	5	33	5.5	50	100	M5x20
1.3.20.052022.00	Ø20 Lower Support Profile	1.23	52	32 <sup>+0.1</sup>	5.8	37	6.5	50	100	M6x25
1.3.25.057024.00	Ø25 Lower Support Profile	1.44	57	36 <sup>+0.1</sup>	6	42	6.5	60	120	M8x30
1.3.30.069027.00	Ø30 Lower Support Profile	2.00	69	42 <sup>+0.15</sup>	7	51	8.5	75	150	M10x35
1.3.40.073030.00	Ø40 Lower Support Profile	2.60	73	50 <sup>+0.15</sup>	8	55	9	100	200	M10x40

Note: Hole dimensions are for informational purposes only.

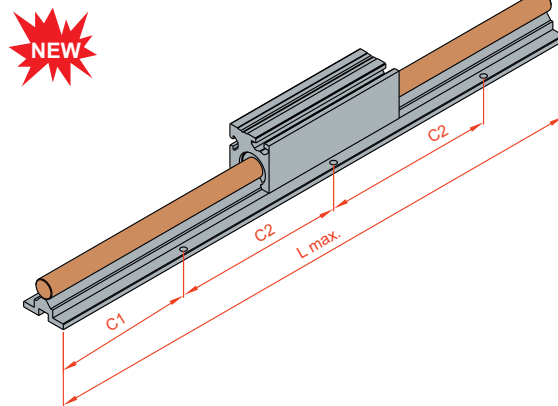
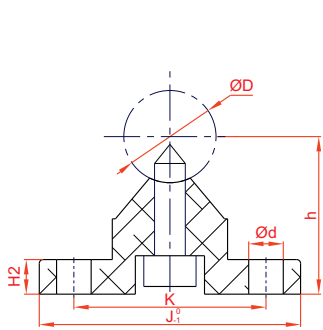

Code	Name of the product	L max	ØD	J	K	h	H2	C1	C2	Ød	Weight
4.1.10.016040.0.12.1	Shaft Lower Sup.Prf+shaf. Ø12 Ck45	6000 mm	12	34	25	20,5	4,5	50	100	4,5	1.59 gr
4.1.10.018045.0.16.1	Shaft Lower Sup.Prf+shaf. Ø16 Ck45	6000 mm	16	40	30	25	5	75	150	5,5	2.56 gr
4.1.10.022052.0.20.1	Shaft Lower Sup.Prf+shaf. Ø20 Ck45	6000 mm	20	45	30	27	5	75	150	5,5	3.5 gr
4.1.10.024057.0.25.1	Shaft Lower Sup.Prf+shaf. Ø25 Ck45	6000 mm	25	55	35	33	6	100	200	6,6	5.3 gr
4.1.10.028069.0.30.1	Shaft Lower Sup.Prf+shaf. Ø30 Ck45	6000 mm	30	60	40	37	7	100	200	6,6	7.38 gr
4.1.10.032073.0.40.1	Shaft Lower Sup.Prf+shaf. Ø40 Ck45	6000 mm	40	75	55	48	9	100	200	9	12.69 gr

Using Area

This piece, which can be easily mounted to T slots on module body via tabs, enables connection of plates to module or multiple modules.

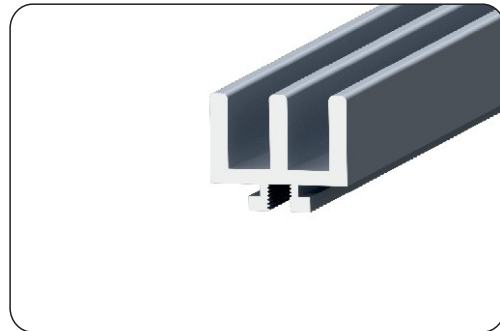
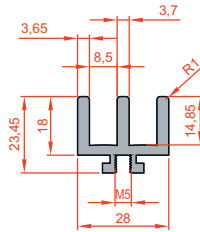

**18x28 Slide Profile**

Code: 1.2.00.018028.00

Designed for use of slide doors on cabins and compartments, it ensures significantly easier assembly. Can constitute reliable connection through anchoring with M5 bolt wherever required on slot of profiles in slot 8 series.

Stock Code	External Dimensions	Material	Moment of Inertia		Moments of Stength		Area	Mass
			$I_x$	$I_y$	$W_x$	$W_y$		
1.2.00.018028.00	18x28 Slider Profile	6063	$1.09\text{cm}^4$	$2.24\text{cm}^4$	$0.92\text{cm}^3$	$1.6\text{cm}^3$	$2.82\text{cm}^2$	0.77 Kg/m

Standard : 6010 mm Lmax : 7200 mm

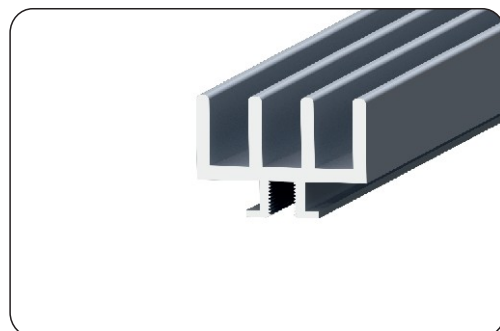
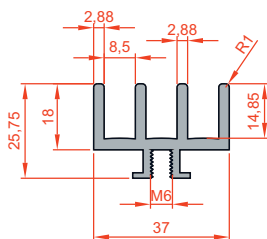

**18x37 (K10) Slide Profile**

Code: 1.2.00.018037.00

Designed for use of slide doors on cabins and compartments, it ensures significantly easier assembly. Can constitute reliable connection through anchoring with M6 bolt wherever required on slot of profiles in slot 10 series.

Stock Code	External Dimensions	Material	Moment of Inertia		Moments of Stength		Area	Mass
			$I_x$	$I_y$	$W_x$	$W_y$		
1.2.00.018037.00	18x37 Slider Profile K10	6063	$1.37\text{cm}^4$	$4.15\text{cm}^4$	$1.05\text{cm}^3$	$2.25\text{cm}^3$	$3.28\text{cm}^2$	0.89 Kg/m

Standard : 6010 mm Lmax : 7200 mm

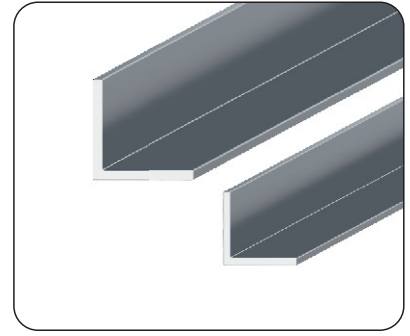
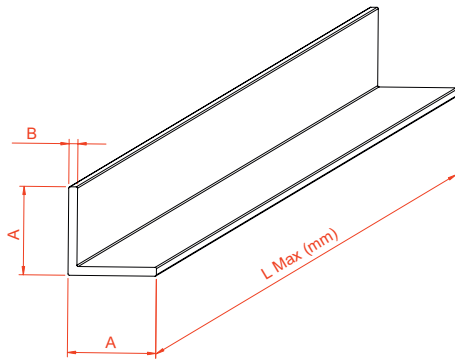

	Stock Code	Product Name	A	B	L (mm)	Material	Weight (Kg/Mt)
NEW	1.4.020020.02	Angle Bracket 20x20x2	20	2	6000	6063 T5	0,20
NEW	1.4.030030.03	Angle Bracket 30x30x3	30	3	6000	6063 T5	0,46
NEW	1.4.040040.03	Angle Bracket 40x40x3	40	3	6000	6063 T5	0,62
NEW	1.4.050050.03	Angle Bracket 50x50x3	50	3	6000	6063 T5	0,79
NEW	1.4.050050.05	Angle Bracket 50x50x5	50	5	6000	6063 T5	1,28
NEW	1.4.076076.08	Angle Bracket 76x76x8	76	8	6000	6063 T5	3,11

### Using Area

It is used as intermediate support in shafts and conveyors.

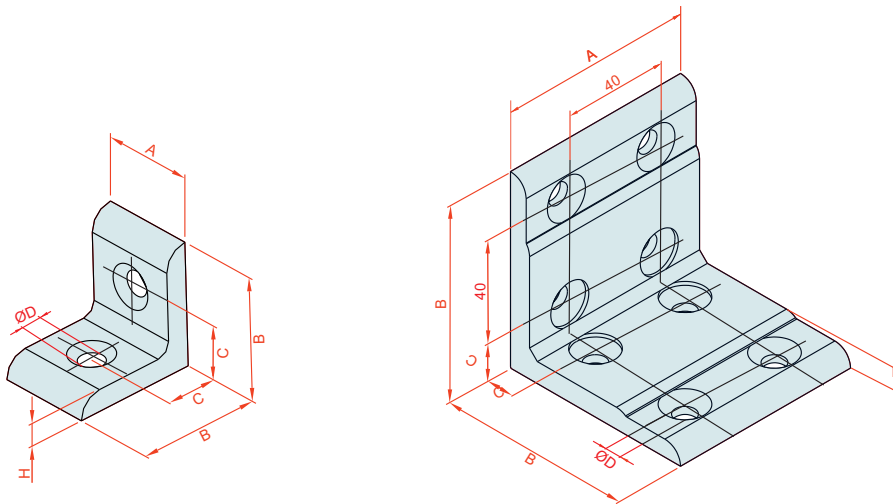
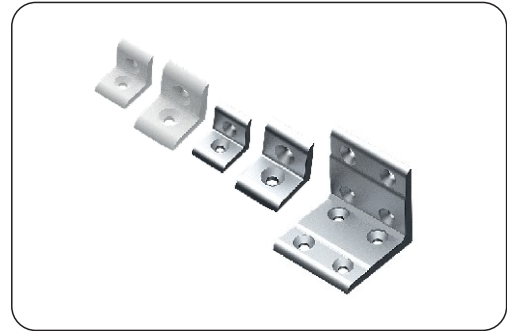

Code	Prf Size	Name of the product	A	B	C	D	H	Material	Weight
2.2.001.08.3030.01	30x30	Straight Angle Connectionı (Sandblasted)	28	29	15	Ø6.5	6	Aluminum	21 gr
2.2.001.08.3030.09	30x30	Straight Angle Connection (Painted Color Gray)	28	29	15	Ø6.5	6	Aluminum	21 gr
2.2.001.10.4040.01	40x40	Straight Angle Connectionı (Sandblasted)	37	37	20	Ø8.2	6.5	Aluminum	39 gr
2.2.001.10.4040.09	40x40	Straight Angle Connection (Painted Color Gray)	37	37	20	Ø8.2	6.5	Aluminum	39 gr
2.2.001.10.4545.01	45x45	Straight Angle Connectionı (Sandblasted)	42	42	22.5	Ø8.2	7	Aluminum	56 gr
2.2.001.10.4545.09	45x45	Straight Angle Connection(Painted Color Gray)	42	42	22.5	Ø8.2	7	Aluminum	56 gr
2.2.001.10.8080.01	80x80	Straight Angle Connection (Sandblasted)	76	76	20	Ø8.5	8,3	Aluminum	206 gr

**Using Area**

Preferred for practical corner connections of light-load constructions. Areas of use include board, frame and simple chassis operations.

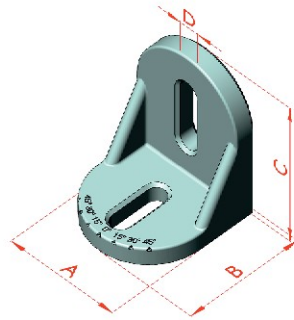

Code	Prf Size	Name of the product	A	B	C	D	COLOUR	Material	Weight
<a href="#">2.2.001.00.3035.06</a>	30-35	Angled Corner Connection	28	30	40	Ø6.5	Sandblasted	Aluminum	22 gr
<a href="#">2.2.001.00.4045.06</a>	40x45	Angled Corner Connection	38	40	50	Ø6.5	Sandblasted	Aluminum	45 gr

**Using Area**

It is preferred for practical connections of light-loaded constructions. Panel, frame and simple chassis applications are some of the usage areas. It provides the opportunity to create connections up to 45 degrees in assembly applications. It is possible to connect to profile channels from outside.

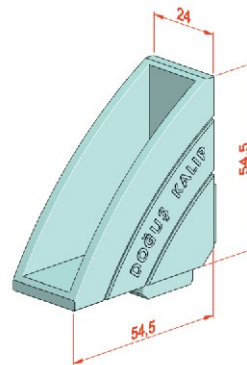
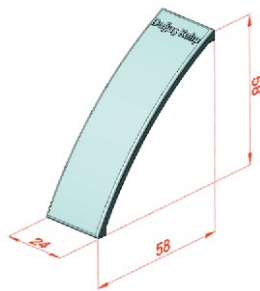

Code	Prf Size	Name of the product	A	D	Material	Weight
<a href="#">2.2.001.08.3030.07</a>	30x30	Narrow Snap Corner Connection Cover	8	Ø6.5	Aluminum	54 gr
<a href="#">2.2.001.10.4545.07</a>	45x45	Narrow Snap Corner Connection Cover	10	Ø8.5	Aluminum	59 gr
<a href="#">2.3.001.3045.00</a>	45x45 30x30	Narrow Snap Corner Connection Cover	-	-	Plastic	7.5 gr

### Using Area

Used for obtaining sound connections on medium -strength chassis constructions. Sandblasted surfaces and genuine caps ensure stylish view.

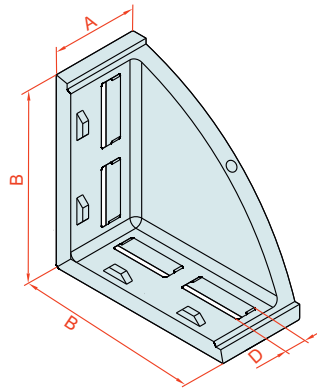
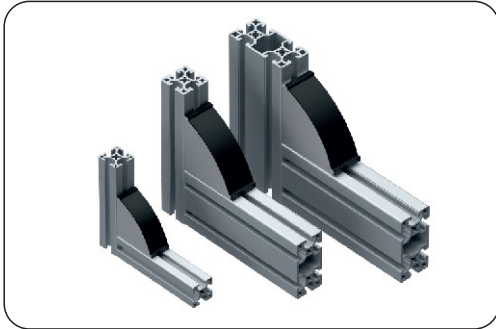

Code	Prf Size	Name of the product	A	B	D	Material	Weight
2.2.001.06.2040.04	20x40	Long Corner Connection	18	38	5.2	Aluminum	16.1 gr
2.2.001.08.3060.04	30x60	Long Corner Connection	27.2	57	6.5	Aluminum	48 gr
2.2.001.10.4080.04	40x80	Long Corner Connection	37.5	78	10.5	Aluminum	114 gr
2.2.001.10.4590.04	45x90	Long Corner Connection	42	85	9	Aluminum	142 gr
2.3.001.3060.03	30x60	Long Corner Connection	-	-	-	Plastic	10 gr
2.3.001.4080.03	40x80	Long Corner Connection	-	-	-	Plastic	10 gr

**Using Area**

Fasteners preferred for assembly operations of constructions where high strength is required. This fastener enables forming corner and T connections. Genuine profile caps ensure hygiene and stylish view.



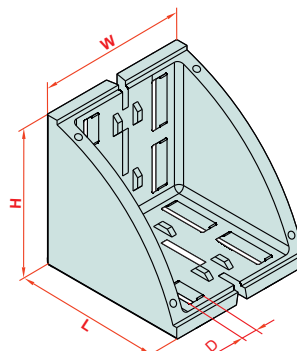
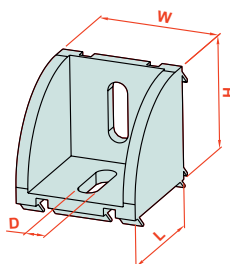
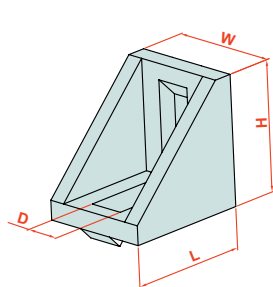
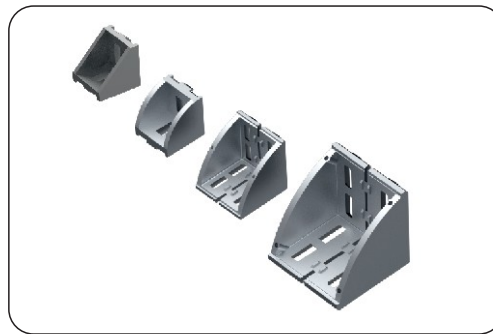
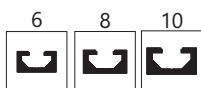

Connection equipments

	Code	Prf Size	Name of the product	L	H	W	D	Material	Weight
	2.2.001.06.2025.03	20x25	Wide Corner Connection	20	20	17.5	5	Aluminum	15.5 gr
<b>NEW</b>	2.2.001.06.2025.33	20x25 (K6)	Wide Corner Connection	20	20	17	5.5	Aluminum	6 gr
	2.2.001.08.3030.03	30x30	Wide Corner Connection	28	28	28	6.5	Aluminum	41.5 gr
<b>NEW</b>	2.2.001.08.3030.33	30x30 (K8)	Wide Corner Connection	27	27	27	6.5	Aluminum	14 gr
	2.2.001.10.4040.03	40x40 (K10)	Wide Corner Connection	37	37	37.7	9	Aluminum	49 gr
	2.2.001.08.4040.03	40x40 (K8)	Wide Corner Connection	37	37	37.7	9	Aluminum	49 gr
<b>NEW</b>	2.2.001.10.4040.33	40x40 (K10)	Wide Corner Connection	37	37	37	9	Aluminum	43 gr
<b>NEW</b>	2.2.001.08.4040.33	40x40 (K8)	Wide Corner Connection	37	37	37	9	Aluminum	43 gr
	2.2.001.10.4545.03	45x45	Wide Corner Connection	44	44	43	9	Aluminum	75 gr
<b>NEW</b>	2.2.001.10.4545.33	45x45	Wide Corner Connection	42	42	42	9	Aluminum	59 gr
	2.2.001.08.6060.03	60x60	Wide Corner Connection	57	57	57	6.5	Aluminum	98 gr
	2.2.001.10.8080.03	80x80 (K10)	Wide Corner Connection	78	78	77	10	Aluminum	226 gr
	2.2.001.08.8080.03	80x80 (K8)	Wide Corner Connection	78	78	77	10	Aluminum	226 gr
	2.2.001.10.9090.03	90x90	Wide Corner Connection	85	84.7	86.5	9	Aluminum	310 gr
<b>NEW</b>	2.3.001.2025.04	20x25	Wide Corner Connection Covers	-	-	-	-	Plastic	2 gr
<b>NEW</b>	2.3.001.2025.09	20x25	Wide Corner Connection Covers	-	-	-	-	Plastic	1 gr
	2.3.001.3030.04	30x30	Wide Corner Connection Covers	-	-	-	-	Plastic	4 gr
<b>NEW</b>	2.3.001.3030.09	30x30 (K8)	Wide Corner Connection Covers	-	-	-	-	Plastic	3 gr
	2.3.001.4040.04	40x40	Wide Corner Connection Covers	-	-	-	-	Plastic	8 gr
<b>NEW</b>	2.3.001.4040.09	40x40	Wide Corner Connection Covers	-	-	-	-	Plastic	5 gr
	2.3.001.4545.04	45x45	Wide Corner Connection Covers	-	-	-	-	Plastic	10 gr
<b>NEW</b>	2.3.001.4545.09	45x45	Wide Corner Connection Covers	-	-	-	-	Plastic	7 gr
	2.3.001.6060.04	60x60	Wide Corner Connection Covers	-	-	-	-	Plastic	8 gr
	2.3.001.8080.04	80x80	Wide Corner Connection Covers	-	-	-	-	Plastic	27 gr
	2.3.001.9090.04	90x90	Wide Corner Connection Covers	-	-	-	-	Plastic	24 gr

Using Area

Used to obtain corner brackets on constructions that require strength. Used for practical and sound assembly of frame, board and cabin applications. Corner bracket caps ensure hygiene and stylish view.

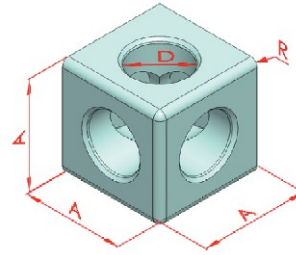
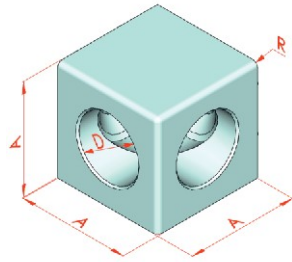
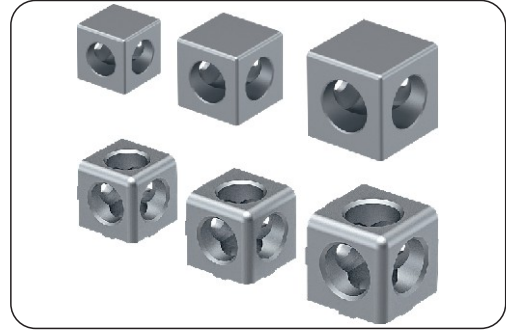
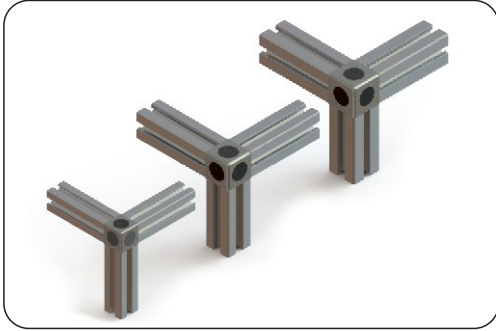

Code	Prf Size	Name of the product	A	D	R	Material	Weight
<b>NEW</b> 2.2.001.08.3030.10	30x30	Two-Way Square Corner Bracket	30	Ø18	1,5	Aluminum	44,26 gr
<b>NEW</b> 2.2.001.08.4040.10	40x40 (K8)	Two-Way Square Corner Bracket	40	Ø24	2,5	Aluminum	106,5 gr
<b>NEW</b> 2.2.001.10.4040.10	40x40 (K10)	Two-Way Square Corner Bracket	40	Ø24	2,5	Aluminum	104 gr
<b>NEW</b> 2.2.001.10.4545.10	45x45 (K10)	Two-Way Square Corner Bracket	45	Ø24	2,5	Aluminum	168 gr
2.2.001.08.3030.08	30x30	Three-Way Square Corner Bracket	30	Ø20,5	2	Aluminum	38,5 gr
2.2.001.08.4040.08	40x40 (K8)	Three-Way Square Corner Bracket	40	Ø26,6	4	Aluminum	94,5 gr
2.2.001.10.4040.08	40x40 (K10)	Three-Way Square Corner Bracket	40	Ø26,6	4	Aluminum	100 gr
2.2.001.10.4545.08	45x45	Three-Way Square Corner Bracket	45	Ø26,6	4	Aluminum	151 gr

İki Yönlü 40x40 (K8)

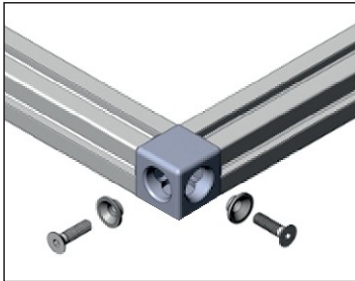

İki Yönlü 40x40 (K10)



Üç Yönlü 40x40 (K8)



Üç Yönlü 40x40 (K10)



### Using Area

It allows corner joints of two profiles. Creates easy assembly by eliminating the drilling process. It is possible to obtain an aesthetic appearance with the plastic covers attached to the exterior surface. Enables corner joint of three profiles. Enables easy assembly since it requires no drilling. Plastic caps mounted on the outer surface ensure stylish view.

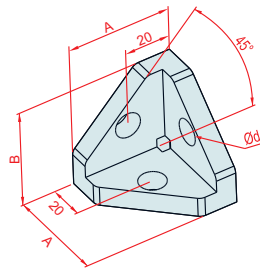
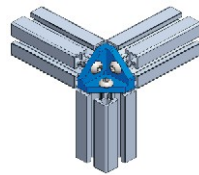
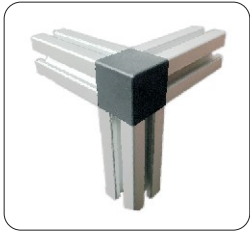
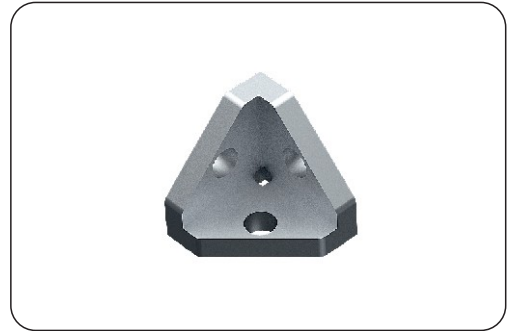

Code	Prf Size	Name of the product	A	B	D	Material	Weight
2.2.001.10.4040.06	40x40 A	Triangular Corner Bracket	36	36	Ø8.5	Aluminum	56 gr
2.3.001.4040.08	40x40 A	Triangular Corner Bracket Cap	40	40	-	Plastic	7 gr
2.3.001.4040.07	40x40	Square Cap	40	40	-	Plastic	13.5 gr



Using Area

Preferred in double or triple corner joints of graded and slotted profiles. Often used in cabin coating of machines. Ensures stylish view thanks to caps.

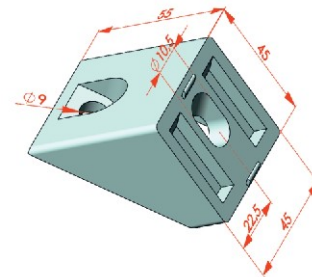
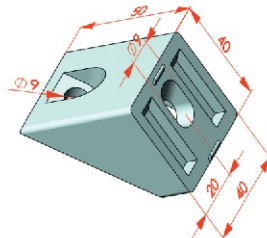
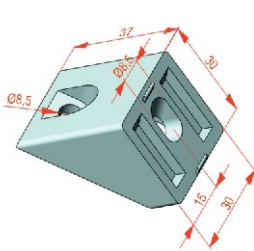
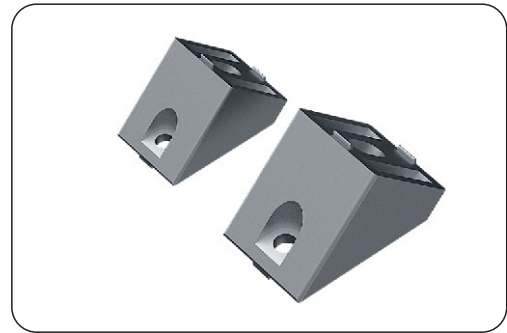
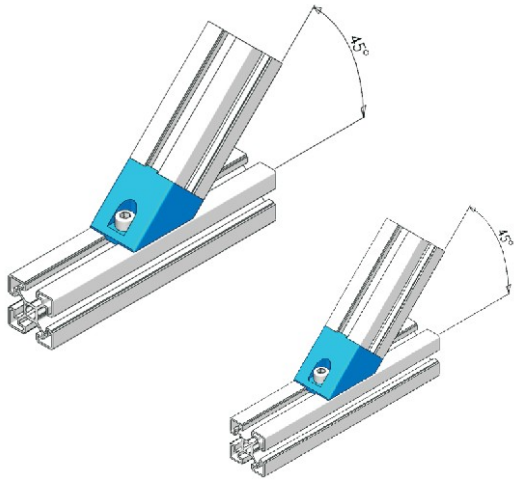

Code	Prf Size	Name of the product	Material	Weight
2.2.001.08.3030.06	30x30	45° Graded Corner Bracket	Aluminum	33 gr
2.2.006.4040.08	40x40 (K8)	45° Graded Corner Bracket	Aluminum	86 gr
2.2.006.4545.10	45x45	45° Graded Corner Bracket	Aluminum	98 gr



**Using Area**

Enables 45-degree connections in assembly applications without need for angular cut. Can be externally connected to profile slots.

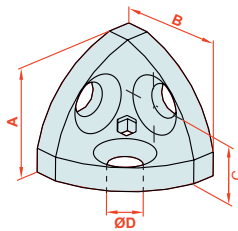
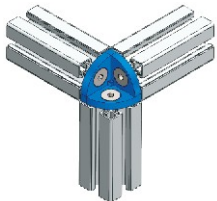
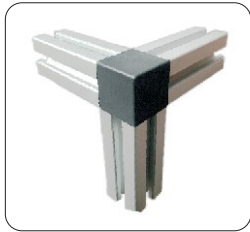
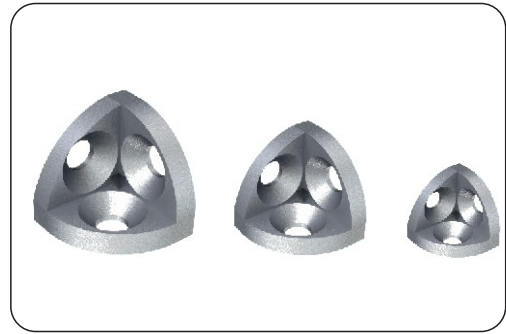
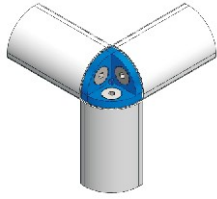

Code	Prf Size	Name of the product	A	B	C	ØD	Material	Weight
2.2.001.06.2020.05	20x20	Radius Corner Joint	18.5	18.5	10	6.5	Zamak	12 gr
2.2.001.08.3030.05	30x30	Radius Corner Joint	28	28	15	8.5	Zamak	42 gr
2.2.001.10.4545.05	45x45	Radius Corner Joint	42	42	22,5	10.5	Zamak	136 gr
2.3.001.2020.05	20x20	Radius Corner Bracket Cap	20	20	3	-	Plastic	2 gr
2.3.001.3030.05	30x30	Radius Corner Bracket Cap	30	30	3	-	Plastic	4 gr
2.3.001.4545.05	45x45	Radius Corner Bracket Cap	45	45	3	-	Plastic	14 gr
2.3.001.2020.07	20x20	Square Cap	20	20	2	-	Plastic	3 gr
2.3.001.3030.07	30x30	Square Cap	30	30	3	-	Plastic	8 gr
2.3.001.4545.07	45x45	Square Cap	45	45	3	-	Plastic	22 gr

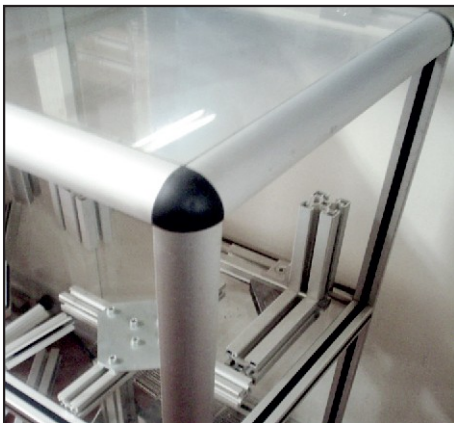

Using Area

Used for corner junctions of radius and square profiles. Preferred for stylish view on table, shelf, booth and board applications.

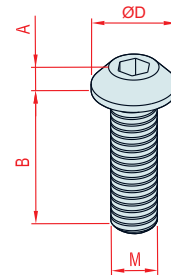
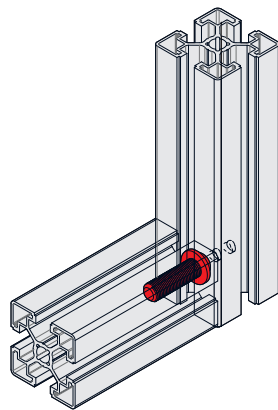
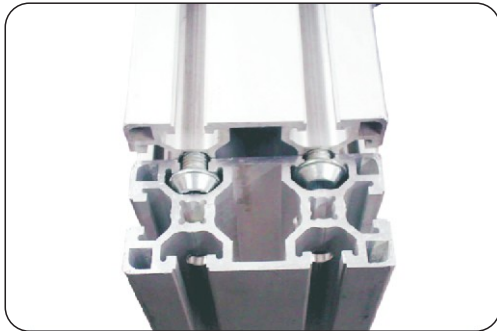

Code		Name of the product	M	A	B	ØD	Material	Weight
2.1.011.06.25	Slot 6	Butt Bolt	M6	3.5	20	10.5	8,8 Steel	4.5 gr
2.1.011.08.30	Slot 8	Butt Bolt	M8	5.2	25	16	8,8 Steel	13 gr
2.1.011.10.30	Slot 10	Butt Bolt	M10	6	30	17.5	8,8 Steel	21 gr

Using Area

Butt joint bolts, which are among alternatives in profile connection systems, are one of the most preferred equipments. Enables screwing to the butt of the other profile, by means of the Allenwrench hole giving to profile slots of. Connection is invisible since it remains in the slots.

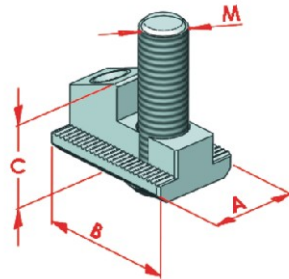
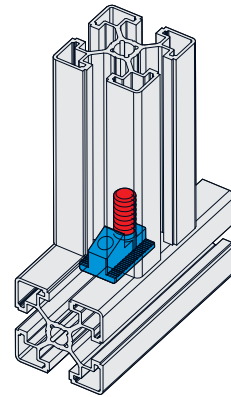
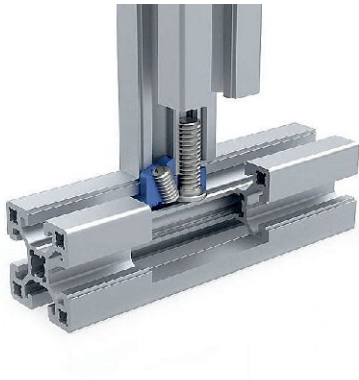
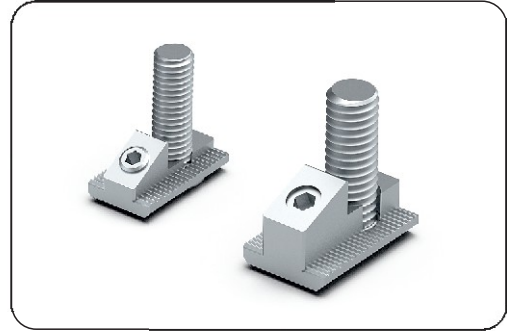

Code		Name of the product	M	A	B	C	Material	Weight
2.1.012.08.01	Slot 8	In-Slot Connection	M8	13.5	21.5	9.8	Steel	15 gr
2.1.012.10.04	Slot 10	In-Slot Connection	M10	19	30	17.5	Steel	39 gr

**Using Area**

Ensures strong connection of two profiles at 90° via screwing without drilling profiles. Stay bolt can be loosened so as to fix the profile anywhere within the slot.

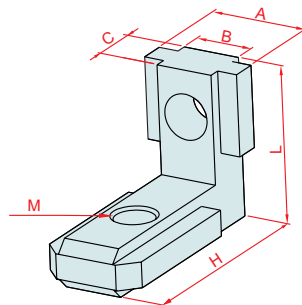
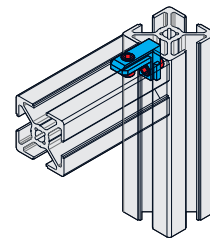
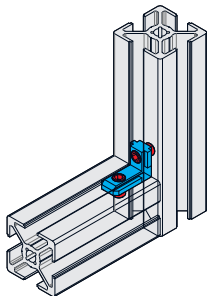
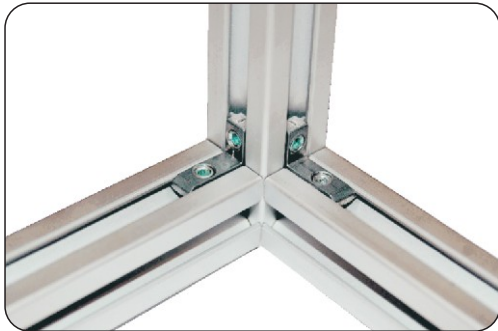

Code		Name of the product	M	A	B	C	L	H	Material	Weight
2.1.010.06.00	Slot 6	Hidden Corner Joint	M5	9	6	4.8	13.5	20	Zinc	6 gr
2.1.010.08.00	Slot 8	Hidden Corner Joint	M6	13	8	6.7	21	30	Zinc	18.5 gr
2.1.010.10.00	Slot 10	Hidden Corner Joint	M8	17	10	8.4	27	40	Zinc	41 gr

Using Area

Often used in assembly of practical operations that do not require strength, such as frame and board.



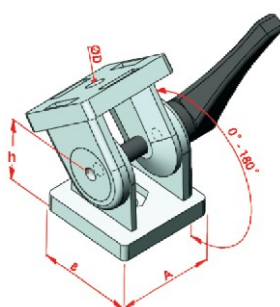
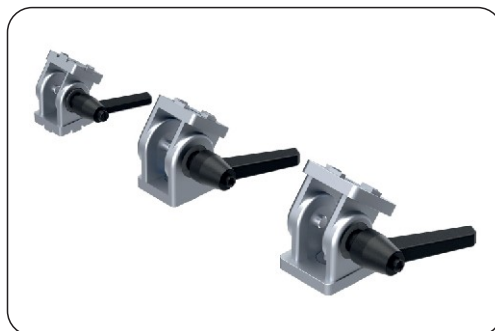
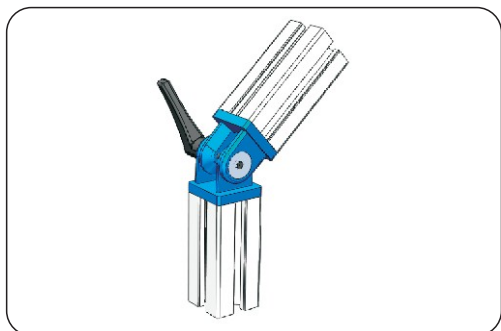
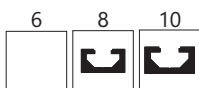

Code	Name of the product	A	B	D	H	Material	Weight
2.2.009.08.3030	30x30 Moving Joint	30	30	Ø8	22.5	Zinc	132,5 gr
2.2.009.10.4040	40x40 Moving Joint	40	40	Ø8.5	30	Zinc	158 gr
2.2.009.10.4545	45x45 Moving Joint	45	45	Ø8.5	30	Zinc	309 gr

Using Area

With its movable connection feature, it allows angled connection of profiles from 90 ° to 270 °. Can be fixed to desired degree thanks to clamping arms. It is based on a load of 1000N in rotation direction. It is possible to use K10 and K8 profiles with connection rings and slots stabilizers.

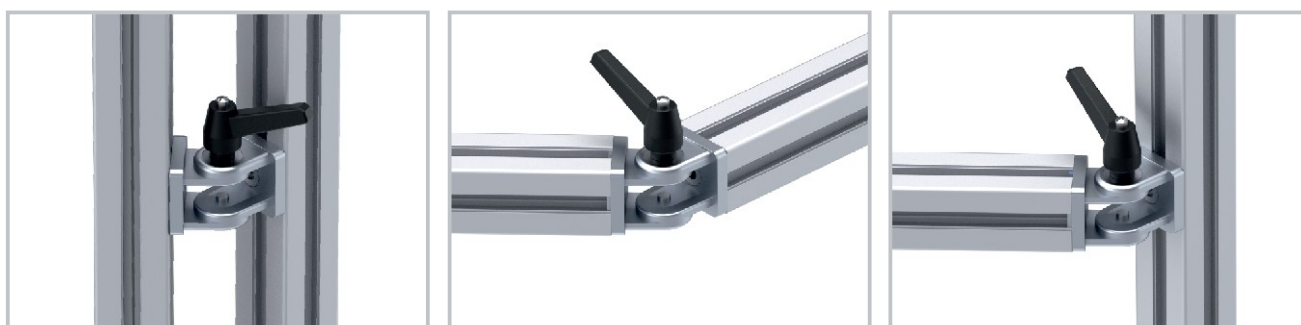

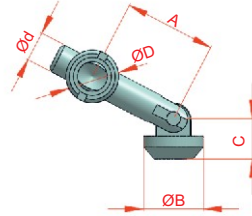

Code		Name of the product	A	B	C	D	d	Material	Weight
2.1.012.08.02	Slot 8	30x30 Puller Connection Angle	12.5	15	9	12	6.8	Steel	22.5 gr
2.1.012.10.02	Slot10	45x45 Puller Connection Angle	26	17	11.5	15	8.5	Steel	53 gr

Using Area

This fitting enables connecting angular-cut profiles to the slot of other profile. Ensures connection of angular-cut surfaces of 60° - 180° on profiles with a slot size of 8 mm & 10 mm.

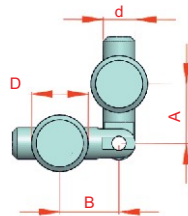
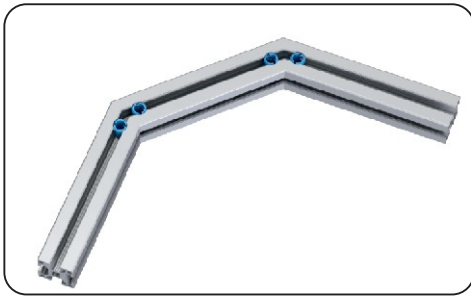

Code		Name of the product	A	B	D	d	Material	Weight
2.1.012.08.03	Slot 8	30x30 Puller Connection with Joint	12.5	11,5	12	6.8	Steel	32.5 gr
2.1.012.10.03	Slot 10	45x45 Puller Connection with Joint	26	26,75	15	8.5	Steel	84 gr

Using Area

Used for end-to-end connection of two profiles through butt. On profiles with slot size of 8 mm & 10 mm, it ensures connection of surfaces cut in angles between 60° - 180°.

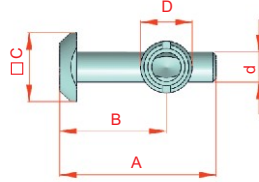
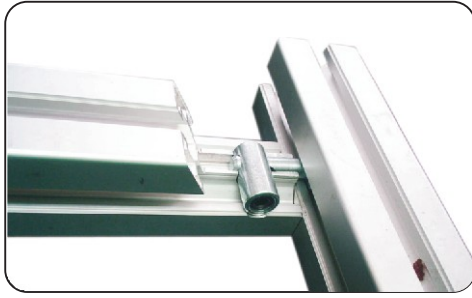

Code		Name of the product	A	B	C	D	d	Material	Weight
2.1.012.08.00	Slot 8	30x30 Plain Puller Connection	29	21	16	12	6.8	Steel	24.5 gr
2.1.012.10.06	Slot10	40x40 Plain Puller Connection	25.5	31	20	15	8.5	Steel	50 gr
2.1.012.10.01	Slot10	45x45 Plain Puller Connection	45.5	31	20	15	8.5	Steel	54 gr

Using Area

Preferred on profiles with slot of 8 mm & 10 mm for connection operations of 90°. Thanks to external fastening feature of puller bracket, the profile can be fixed wherever required.

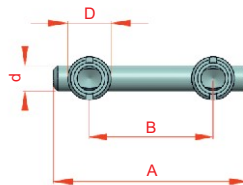
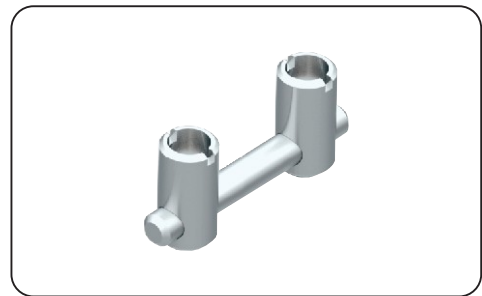
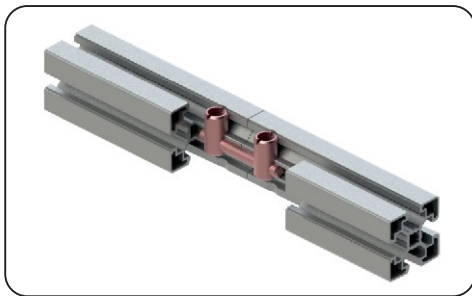

Code		Name of the product	A	B	D	d	Material	Weight
2.1.012.10.05	Slot10	Puller Connection Butt	68	43	15	8.8	Steel	80.5 gr

Using Area

Preferred for use in connection applications of 180° on profiles with slot size of 10 mm. Enables use through end-to-end combination of profiles on the same plane.

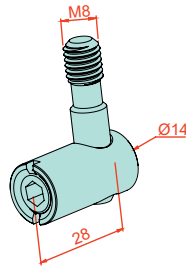
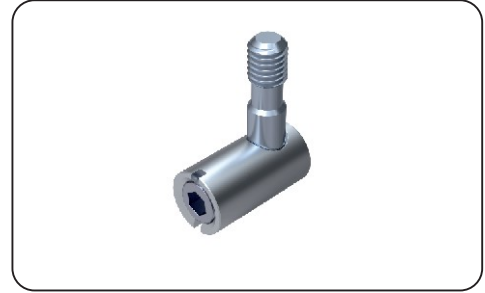

Code		Name of the product	Material	Weight
2.1.012.00.02	Slotl 8-10	Puller Type Connection with T Nut	Çelik	35 gr

#### Using Area

Profile connection application with a channel size of 8 to 10 mm- in the production of the products. Profiles at 90° angles allows them to be used in combination.

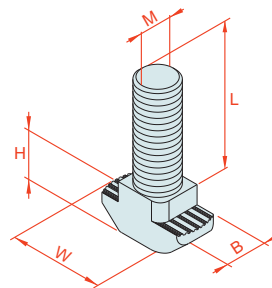
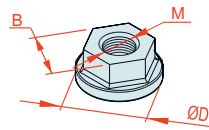
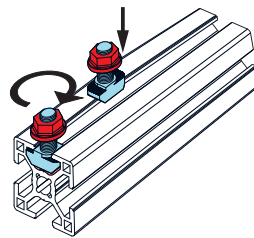
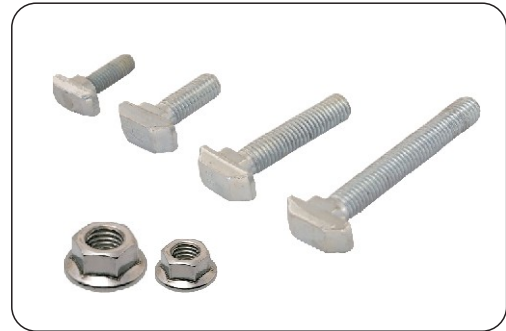
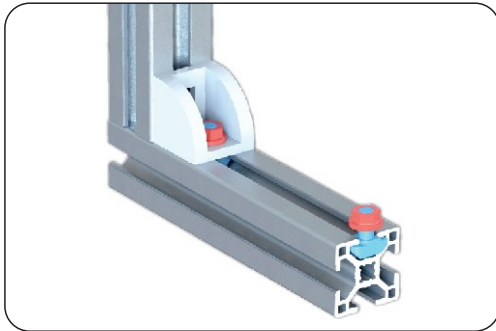

Code		Name of the product	D	L	M	H	W	B	Material	Weight
2.1.002.08.0620	Slotl 8	M6x20 Studded Knurled Nut	-	20	6	6,8	16	8	8,8 Steel	7.5 gr
2.1.002.08.0625	Slotl 8	M6x25 Studded Knurled Nut	-	25	6	6,8	16	8	8,8 Steel	8 gr
2.1.002.10.0825	Slotl 10	M8x25 Studded Knurled Nut	-	22	8	9,7	19,5	8,5	8,8 Steel	14 gr
2.1.002.10.0830	Slotl 10	M8x30 Studded Knurled Nut	-	30	8	9,7	19,5	8,5	8,8 Steel	16 gr
2.1.002.10.0840	Slotl 10	M8x40 Studded Knurled Nut	-	40	8	9,7	19,5	8,5	8,8 Steel	18.5 gr
2.1.002.10.0860	Slotl 10	M8x60 Studded Knurled Nut	-	60	8	9,7	19,5	8,5	8,8 Steel	25.5 gr
2.1.009.00.06	Slotl 8	Round Head Washer Nut	Ø14	-	6	-	-	10	8,8 Steel	3 gr
2.1.009.01.08	Slot 8	M8 Round Head Washer Nut Small K8	Ø16,9	-	8	-	-	13	8,8 Steel	7.5gr
2.1.009.00.08	Slot10	M8 Round Head Washer Nut Big K10	Ø21	-	8	-	-	13	8,8 Steel	9.5 gr

Using Area

Preferred for use in assembly operations that require resistance. Facilitates connection of parts to profiles with a slot size of 8 mm & 10 mm. Knurled nuts of various size are available depending on the height of fitting.

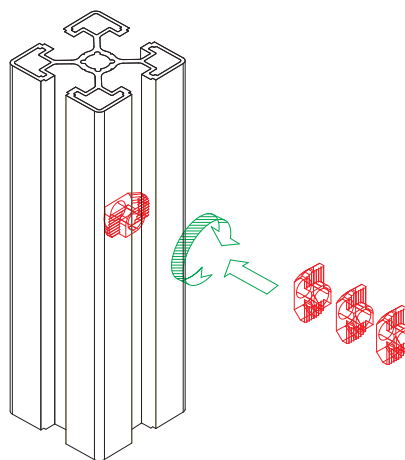
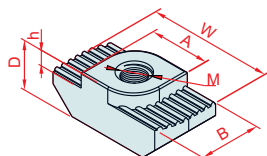
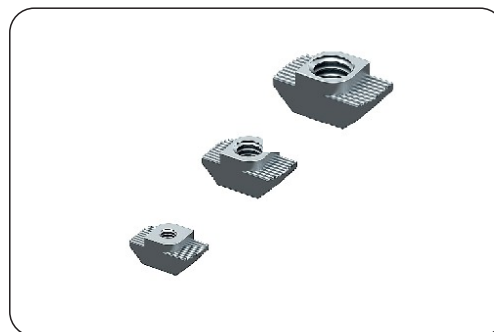
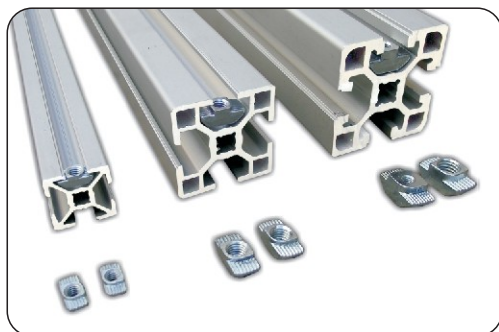
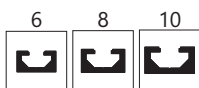

Code		Name of the product	M	B	W	D	H	A	Material	Weight
2.1.001.06.04	Slot 6	Knurled Nut	M4	5.7	11.4	4.1	1.2	5.6	8,8 Steel	1.2 gr
2.1.001.06.05	Slot 6	Knurled Nut	M5	5.7	11.4	4.1	1.2	5.6	8,8 Steel	1 gr
2.1.001.08.04	Slot 8	Knurled Nut	M4	7.9	16	6.3	2	7.7	8,8 Steel	3.6 gr
2.1.001.08.05	Slot 8	Knurled Nut	M5	7.9	16	6.3	2	7.7	8,8 Steel	3.3 gr
2.1.001.08.06	Slot 8	Knurled Nut	M6	7.9	16	6.3	2	7.7	8,8 Steel	3 gr
2.1.001.10.04	Slot 10	Knurled Nut	M4	10	19	8.7	3	9.8	8,8 Steel	7.5 gr
2.1.001.10.05	Slot 10	Knurled Nut	M5	10	19	8.7	3	9.8	8,8 Steel	7 gr
2.1.001.10.06	Slot 10	Knurled Nut	M6	10	19	8.7	3	9.8	8,8 Steel	6.5 gr
2.1.001.10.08	Slot 10	Knurled Nut	M8	10	19	8.7	3	9.8	8,8 Steel	5.5 gr
2.1.001.08.06.00	Slot 8	Knurled Nut Stainless	M6	7,9	16	6.3	2	7.7	Stainless Steel	2.7 gr
2.1.001.10.06.00	Slot 10	Knurled Nut Stainless	M6	10	19	8.7	3	9.8	Stainless Steel	5.9 gr
2.1.001.10.08.00	Slot 10	Knurled Nut Stainless	M8	10	19	8.7	3	9.8	Stainless Steel	5 gr

Using Area

Any fastener and apparatus can be connected to profile slots by means of knurled nut. Knurled structure gets in touch with interior of profile and prevents sliding and loosening.

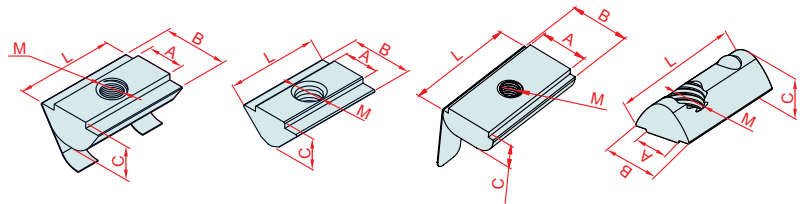
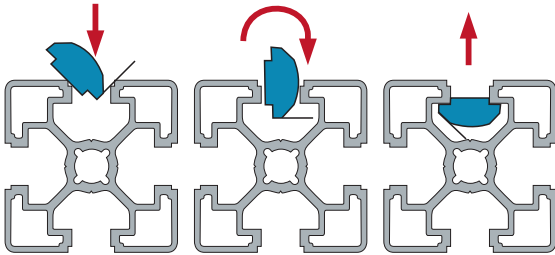
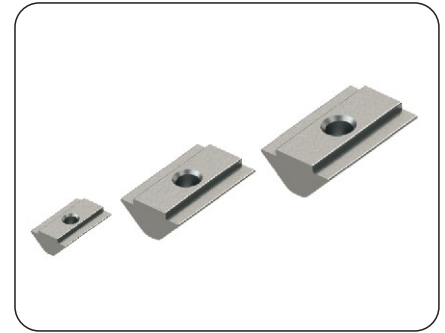
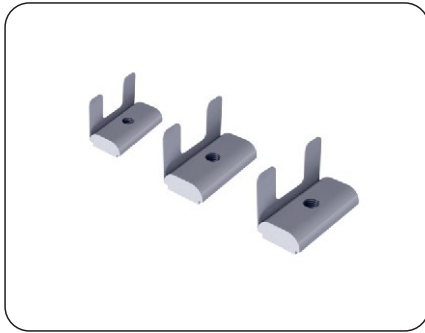

Code	Slot	Name of the product	M	A	B	C	L	Material	Weight
<b>NEW</b> 2.1.003.08.04.001	Slot 8	30x30 Spring Nut Outboard M4	M4	8	10	4.5	20	ST 37	6 gr
<b>NEW</b> 2.1.003.08.05.001	Slot 8	30x30 Spring Nut Outboard M4	M5	8	10	4.5	20	ST 37	5 gr
<b>NEW</b> 2.1.003.08.06.001	Slot 8	30x30 Spring Nut Outboard M4	M6	8	10	4.5	20	ST 37	5 gr
<b>NEW</b> 2.1.003.08.08.001	Slot 8	30x30 Spring Nut Outboard M4	M8	8	10	4.5	20	ST 37	4 gr
<b>NEW</b> 2.1.003.08.04.002	Slot 8	40x40 Spring Nut Outboard M4	M4	8	12	5.45	20	ST 37	12 gr
<b>NEW</b> 2.1.003.08.05.002	Slot 8	40x40 Spring Nut Outboard M4	M5	8	12	5.45	20	ST 37	12 gr
<b>NEW</b> 2.1.003.08.06.002	Slot 8	40x40 Spring Nut Outboard M4	M6	8	12	5.45	20	ST 37	12 gr
<b>NEW</b> 2.1.003.08.08.002	Slot 8	40x40 Spring Nut Outboard M4	M8	8	12	5.45	20	ST 37	10 gr
2.1.003.08.04	Slot 8	Spring Nut M4	M4	8	13	5.5	16	ST 37	3.8 gr
2.1.003.08.05	Slot 8	Spring Nut M4	M5	8	13	5.5	16	ST 37	4 gr
2.1.003.08.06	Slot 8	Spring Nut M4	M6	8	13	5.5	16	ST 37	5.5 gr
2.1.003.08.08	Slot 8	Spring Nut M4	M8	8	13	5.5	16	ST 37	4.5 gr
2.1.003.10.04	Slot 10	Spring Nut M4	M4	10	15	7.5	20	ST 37	12 gr
2.1.003.10.05	Slot 10	Spring Nut M4	M5	10	15	7.5	20	ST 37	11.5 gr
2.1.003.10.06	Slot 10	Spring Nut M4	M6	10	15	7.5	20	ST 37	11.5 gr
2.1.003.10.08	Slot 10	Spring Nut M4	M8	10	15	7.5	20	ST 37	10.5 gr
2.1.007.06.04	Slot 6	Module T Nut	M4	6.1	11	5.5	16	ST 37	4 gr
2.1.007.06.05	Slot 6	Module T Nut	M5	6.1	11	5.5	16	ST 37	4 gr
2.1.007.06.06	Slot 6	Module T Nut	M6	6.1	11	5.5	16	ST 37	3 gr
<b>NEW</b> 2.1.003.08.04.002	Slot 8	Spring Nut Outboard M4	M4	8	12	5.45	20	ST 37	8 gr
<b>NEW</b> 2.1.003.08.05.002	Slot 8	Spring Nut Outboard M4	M5	8	12	5.45	20	ST 37	8 gr
<b>NEW</b> 2.1.003.08.06.002	Slot 8	Spring Nut Outboard M4	M6	8	12	5.45	20	ST 37	8 gr
<b>NEW</b> 2.1.003.08.08.002	Slot 8	Spring Nut Outboard M4	M8	8	12	5.45	20	ST 37	6 gr
<b>YENI</b> 2.1.013.08.04	Slot 8	Ball T Channel Nut	M4	8	13	7.5	21	ST 235	10 gr
<b>YENI</b> 2.1.013.08.05	Slot 8	Ball T Channel Nut	M5	8	13	7.5	21	ST 235	90 gr
<b>YENI</b> 2.1.013.08.06	Slot 8	Ball T Channel Nut	M6	8	13	7.5	21	ST 235	80 gr
<b>YENI</b> 2.1.013.08.08	Slot 8	Ball T Channel Nut	M8	8	13	7.5	21	ST 235	80 gr

Using Area

Spring nuts, which enable remaining stable within slot, allow for assembly at desired position. Can be used on profile types with a slot size of 10 mm. Module T nuts, Suitable for use on profiles and modules with a slot size of 6 mm. Can be employed either as alternative fitting or for connections of switches and sensors on modules and bedding.

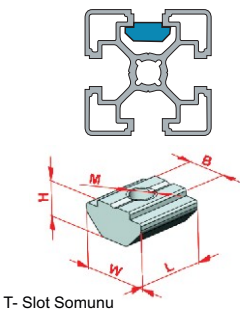
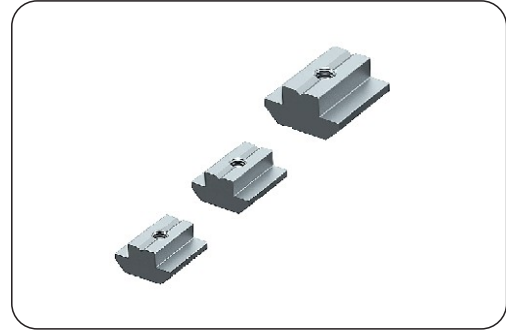

T- Slot Somunu

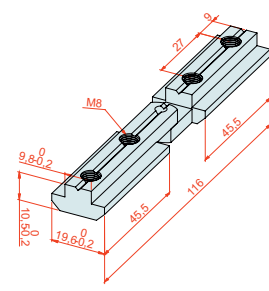

Dereceli Bağlantı Somunları

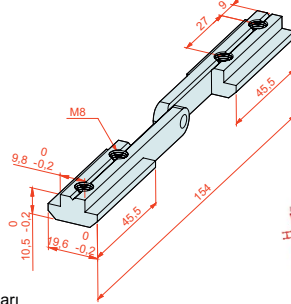

Uzun T Slot Somunu

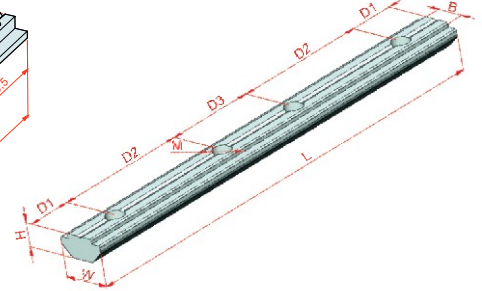

It is used in end-to-end profile connections and strong connection formations.

Code	Icon	Name of the product	Mct	B	W	L	D3	D2	D1	H	Material	Weight
2.1.008.06.100	Slot 6	Long T-slot Nut	M5	6	10	100	20	30	10	5	ST 37	29 gr
2.1.008.08.120	Slot 8	Long T-slot Nut	M6	7,8	16	120	35	35	7,5	6	ST 37	77.5 gr
2.1.008.10.140	Slot 10	Long T-slot Nut	M8	10	20	140	30	40	15	10,5	ST 37	150 gr

Code	Icon	Name of the product	Mct	B	W	L	H	Material	Weight
2.1.006.06.04	Slot 6	T Slot Nuts M4	M4	6	10	10	5	ST 37	2.5 gr
2.1.006.06.05	Slot 6	T Slot Nuts M4	M5	6	10	10	5	ST 37	2 gr
2.1.006.06.06	Slot 6	T Slot Nuts M4	M6	6	10	10	5	ST 37	2 gr
2.1.006.08.04	Slot 8	T Slot Nuts M4	M4	7.8	16	16	6	ST 37	9 gr
2.1.006.08.05	Slot 8	T Slot Nuts M4	M5	7.8	16	16	6	ST 37	8.5 gr
2.1.006.08.06	Slot 8	T Slot Nuts M4	M6	7.8	16	16	6	ST 37	8.5 gr
2.1.006.08.08	Slot 8	T Slot Nuts M4	M8	7.8	16	16	6	ST 37	7.5 gr
2.1.006.10.04	Slot 10	T Slot Nuts M4	M4	10.1	20	20	10,5	ST 37	21.5 gr
2.1.006.10.05	Slot 10	T Slot Nuts M4	M5	10.1	20	20	10,5	ST 37	20.5 gr
2.1.006.10.06	Slot 10	T Slot Nuts M4	M6	10.1	20	20	10,5	ST 37	19.5 gr
2.1.006.10.08	Slot 10	T Slot Nuts M4	M8	10.1	20	20	10,5	ST 37	18.5 gr

Code	Icon	Name of the product	Material	Weight
2.2.011.10.0114.08	Slot 8	Horizontal Degree Connection Nut	Karbon çeliği	100 gr
2.2.011.10.0154.08	Slot 8	Vertical Grade Joint Nut	Karbon çeliği	110 gr

### Using Area

Thanks to wide retention surface, they are suitable where strong connection is required. Unlike knurled nuts, they cannot be mounted on slot from upper part; they are placed in the slot from the beginning of profile. Ensures 180° end-to-end connection of two profiles with slot size of 10 mm in strength-requiring assembly applications. Provides profile slot with a wider retention surface.



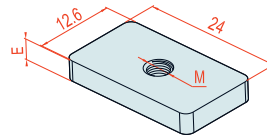
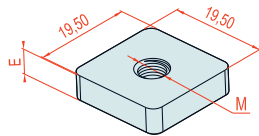
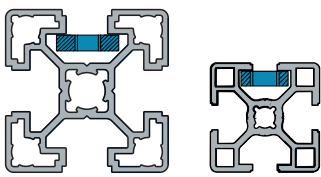
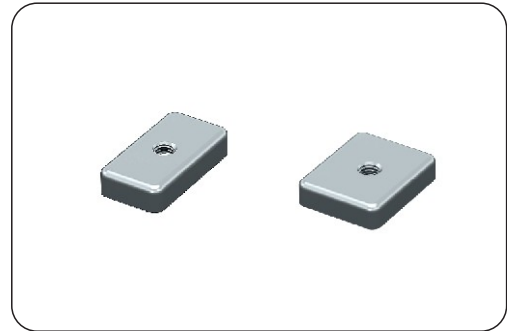
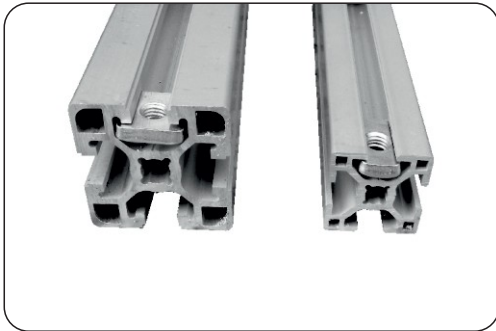

Code		Name of the product	M	E	Material	Weight
2.1.005.08.04	Slot 8	Rectangular Nut M4	M4	5	HRP	10.5 gr
2.1.005.08.05	Slot 8	Rectangular Nut M4	M5	5	HRP	10 gr
2.1.005.08.06	Slot 8	Rectangular Nut M4	M6	5	HRP	10 gr
2.1.005.08.08	Slot 8	Rectangular Nut M4	M8	5	HRP	9 gr
2.1.004.10.04	Slot 10	Square Nut M4	M4	5	HRP	13.5 gr
2.1.004.10.05	Slot 10	Square Nut M4	M5	5	HRP	13 gr
2.1.004.10.06	Slot 10	Square Nut M4	M6	5	HRP	13 gr
2.1.004.10.08	Slot 10	Square Nut M4	M8	5	HRP	12 gr
2.1.004.10.10	Slot 10	Square Nut M4	M10	5	HRP	10.5 gr

Using Area

**Rectangular Nuts:** Used for connection of fastening equipments and accessories on profiles with a slot size of 8 mm. It is possible to mount any required piece by means of assembly from the head of profile slots. **Square Nuts:** Used for connection of fastening equipments and accessories on profiles with a slot size of 10 mm. It is possible to mount any required piece by means of assembly from the head of profile slots.

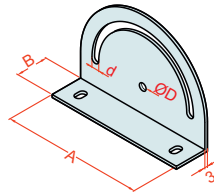

Code		Name of the product	A	B	d	Ø D	Material	Weight
2.2.007.08	Slot 8	Shelf Shim	120	30	6.5	6.5	HRP	247.5 gr
2.2.007.10	Slot 10	Shelf Shim	120	38	8.5	8.5	HRP	242.5 gr

**Place of use**

Work and assembly table shelves at up to 180° angle  
Connection that allows it to be fixed wherever desired element. Use in 8 mm & 10 mm Slot size profiles suitable.

**Using Area**

This fastener enables fixing shelves of work and assembly benches anywhere at an angle of 180°. Suitable for use on profiles with slot size of 8 mm & 10mm.

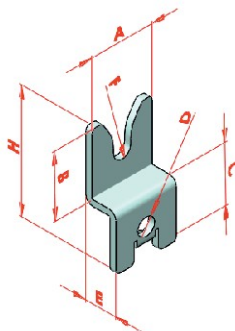
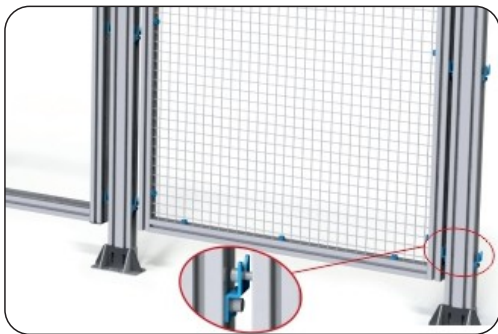

Code	Name of the product	A	B	C	ØD	E	F	H	Material	Weight
2.2.002.10.180180.10	Parallel Connecting Piece	30	30	27	8,5	15	8,5	57	Steel	38.5 gr

**Using Area**

Auxiliary components used in connection of safety cabin and board sashes. Thanks to dismantling feature, it can be easily removed and number of sashes can be changed.

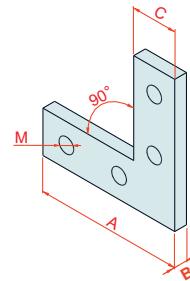
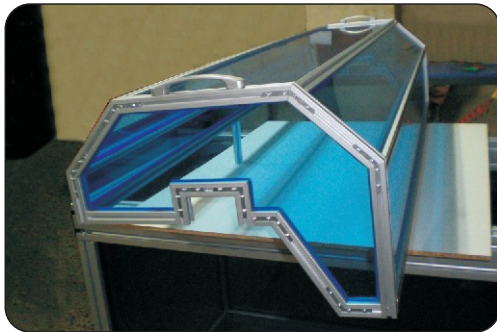

Code	Prf Size	Name of the product	A	B	C	M	Material	Weight
<a href="#">2.2.011.06.090.20</a>	20x20	90° Connecting Piece	45	3	9.3	M4	HRP	17.5 gr
<a href="#">2.2.011.06.090.25</a>	25x25	90° Connecting Piece	45	4	12.3	M5	HRP	30 gr
<a href="#">2.2.011.08.090</a>	30x30	90° Connecting Piece	45	4	14	M6	HRP	33.5 gr
<a href="#">2.2.011.10.090.40</a>	40x40	90° Connecting Piece	61,5	4	16,5	M6	HRP	52.3 gr
<a href="#">2.2.011.10.090</a>	45x45	90° Connecting Piece	55	5	19,5	M8	HRP	71 gr

**Using Area**

End-to-end connections of 45-degree cut profiles create 90-degree connection constructions. They preferred for external and practical connections of angled profiles.

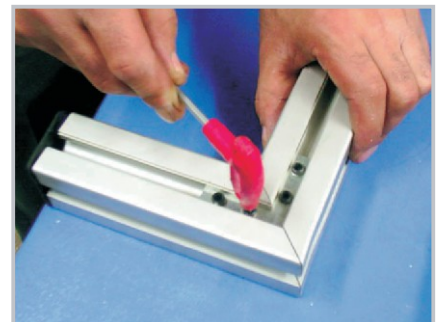
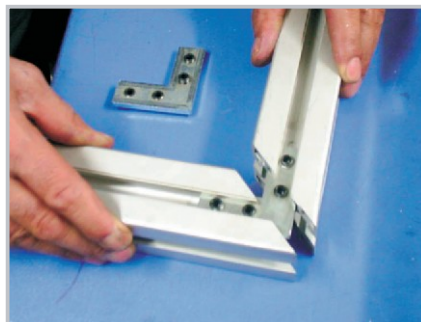
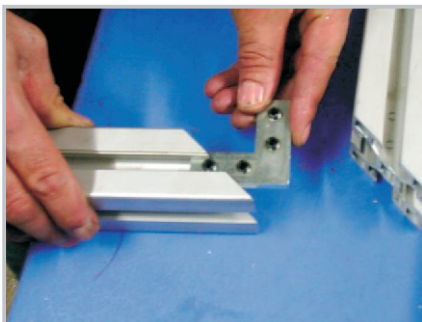

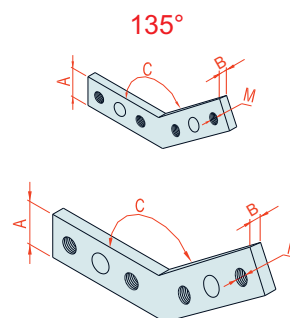
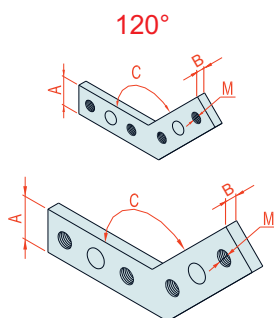

Code	Prf Size	Name of the product	A	B	C	M	Material	Weight
2.2.011.06.120.20	20x20	120° Connecting Piece	9.3	3	120	M4	HRP	17 gr
2.2.011.06.120.25	25x25	120° Connecting Piece	12.3	4	120	M5	HRP	27 gr
2.2.011.08.120	30x30	120° Connecting Piece	14	4	120	M6	HRP	43 gr
2.2.011.10.120.40	40x40	120° Connecting Piece	16.6	4	120	M6	HRP	49 gr
2.2.011.10.120	45x45	120° Connecting Piece	19.5	5	120	M8	HRP	92 gr
2.2.011.06.135.20	20x20	120° Connecting Piece	9.3	3	135	M4	HRP	16 gr
2.2.011.06.135.25	25x25	120° Connecting Piece	12.3	4	135	M5	HRP	27 gr
2.2.011.08.135	30x30	120° Connecting Piece	14	4	135	M6	HRP	41 gr
2.2.011.10.135.40	40x40	120° Connecting Piece	16.5	4	135	M6	HRP	48 gr
2.2.011.10.135	45x45	120° Connecting Piece	19.5	5	135	M8	HRP	88 gr

**Using Area**

Ensures end-to-end connection of profiles cut in an angle of 120° & 135° preferred for external and practical connection of angular profiles.

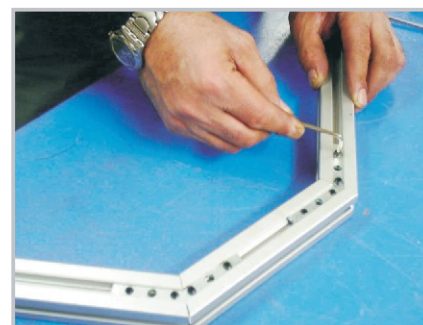
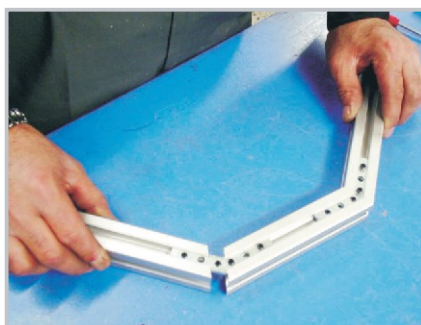

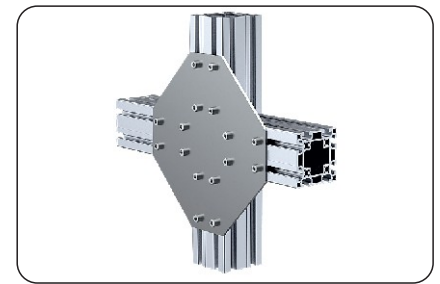
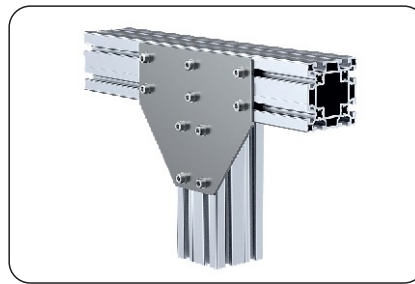
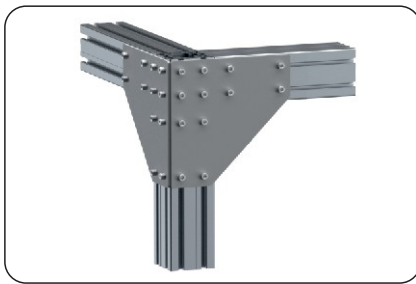

**Flat Connection Plates**

Code	Name of the product	Act B	C	ØD	L	K	Material	Weight	
2.2.002.10.4080.01	Additional Plain Connection Plate	72.5	40	40	6.5	150	4	HRP	330 gr
2.2.002.10.4590.01	Additional Plain Connection Plate	85	45	45	8.5	175	5	HRP	564 gr

**Two-Way Connection Plates**

Code	Prf Size	Name of the product	Act B	ØD	K	Material	Weight	
2.2.002.06.2025.02	20x25	Two-Way Connection Plate	75	75	5	3	HRP	96.5 gr
2.2.002.08.3030.02	30x30	Two-Way Connection Plate	80	80	6.5	3	HRP	119 gr
2.2.002.10.4040.02	40x40	Two-Way Connection Plate	110	110	6.5	3	HRP	218 gr
2.2.002.10.4545.02	45x45	Two-Way Connection Plate	120	120	8.5	3	HRP	256 gr
2.2.002.10.4590.02	45x90	Two-Way Connection Plate	180	180	8.5	4	HRP	850 gr
2.2.002.10.8080.02	80x80	Two-Way Connection Plate	200	200	6.5	4	HRP	990 gr
2.2.002.10.9090.02	90x90	Two-Way Connection Plate	240	240	8.5	5	HRP	1.782 gr
2.2.002.10.100100.02	100x100	Two-Way Connection Plate	250	250	8.5	5	HRP	1.922 gr

**Three Way Connection Plates**

Code	Prf Size	Name of the product	A	B	ØD	K	Material	Weight
2.2.002.06.2025.03	20x25	Three-Way Connection Plate	75	86	5	3	HRP	109.5 gr
2.2.002.08.3030.03	30x30	Three-Way Connection Plate	90	150	6.5	3	HRP	221.5 gr
2.2.002.10.4040.03	40x40	Three-Way Connection Plate	110	150	6.5	3	HRP	280 gr
2.2.002.10.4545.03	45x45	Three-Way Connection Plate	120	160	8.5	3	HRP	322 gr
2.2.002.10.4590.03	45x90	Three-Way Connection Plate	170	130	8.5	4	HRP	622 gr
2.2.002.10.8080.03	80x80	Three-Way Connection Plate	160	220	6.5	4	HRP	900 gr
2.2.002.10.9090.03	90x90	Three-Way Connection Plate	200	250	8.5	5	HRP	1.581 gr
2.2.002.10.100100.03	100x100	Three-Way Connection Plate	230	290	8.5	5	HRP	2.078 gr

**Four Way Connection Plates**

Code	Prf Size	Name of the product	A	B	ØD	K	Material	Weight
2.2.002.06.2025.04	20x25	Three-Way Connection Plate	130	130	5	3	HRP	248 gr
2.2.002.08.3030.04	30x30	Three-Way Connection Plate	150	150	6.5	3	HRP	334 gr
2.2.002.10.4040.04	40x40	Three-Way Connection Plate	150	150	6.5	3	HRP	374 gr
2.2.002.10.4545.04	45x45	Three-Way Connection Plate	180	180	8.5	4	HRP	689 gr
2.2.002.10.8080.04	80x80	Three-Way Connection Plate	200	220	6.5	4	HRP	1.180 gr
2.2.002.10.9090.04	90x90	Three-Way Connection Plate	311	311	8.5	5	HRP	2.739 gr

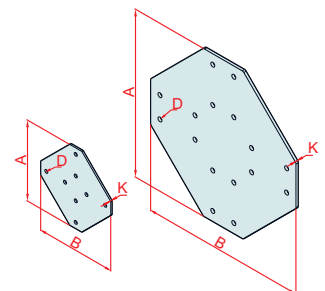
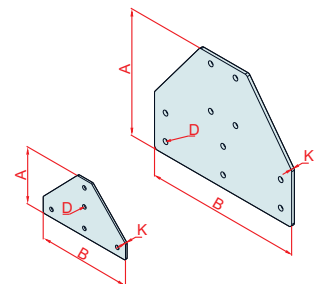
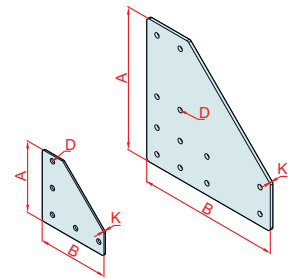
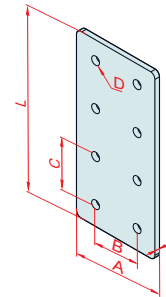

**Using Area**

It's possible to mount more than one profile by using bolts without making any holes on profiles. It's mostly used on machines and conveyors's feets and it provides an aesthetics apperiance. It's used as support on areas which need strength Also it provides alternative option connection as support

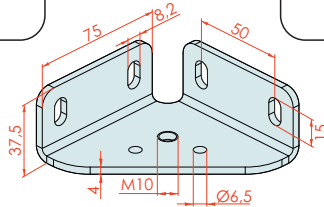
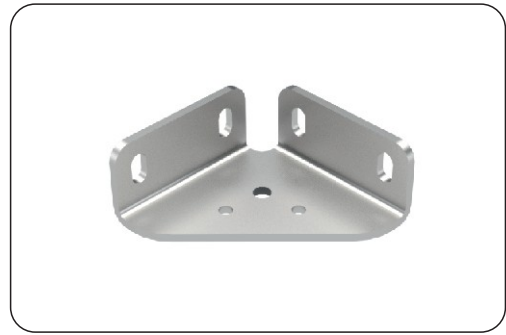

Code	Name of the product	Material	Weight
2.2.002.040045.00.10	Corner Foot Connection Piece	DKP	45 gr

**Using Area**

1-The connection sheet, which can be used as a strong corner connection, is also made of mdf, sheet metal, plexi etc. thanks to the connection holes on its outer surface. It enables the assembly of products.

2-In addition to the corner connection, it can be used as a foot connection plate. Thanks to the internal connection system, aesthetic appearance and durable connection are provided. It is possible to make different foot connections by pulling the M12 and M16 guides instead of the standard M10 guides.

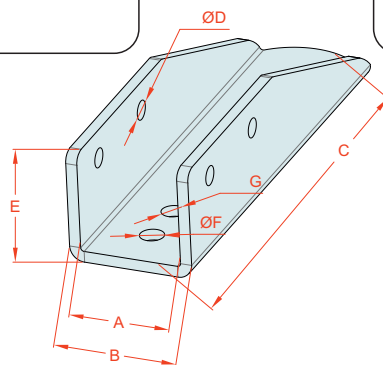

Code	Name of the product	A	B	C	ØD	E	ØF	G	Material	Weight
2.2.001.040080.00.10	40x80 Feet Wheel Connection Piece	40	50	190	Ø8,50	40	Ø10,50	M12	HRP SAC	724 gr
2.2.001.045090.00.10	45x90 Feet Wheel Connection Piece	45	55	198	Ø8,50	50	Ø10,50	M12	HRP SAC	885 gr

**Using Area**

40x80 & 45x90 sigma profile and wheel can be used of assembly to the plastic feets.

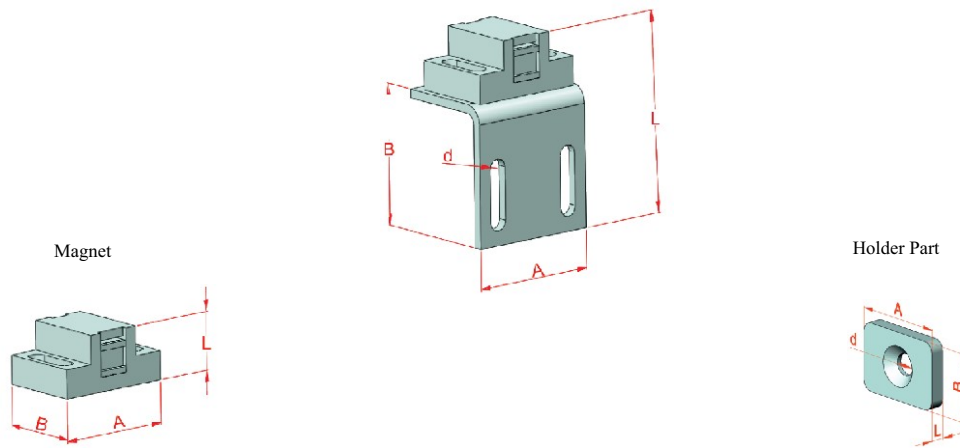
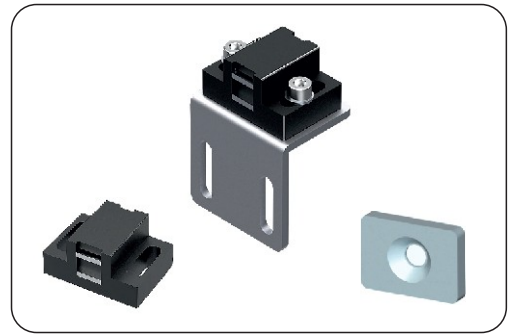
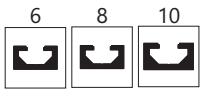

Code		Name of the product	A	B	L	Ød	Material	Weight
2.2.004.2025	Slot 6	Magnet Set	45	20	40	Ø5.5	Plate+Plastic	88.5 gr
2.2.004.3035	Slot 8	Magnet Set	45	35	55	Ø6.5	Plate+Plastic	104 gr
2.2.004.4045	Slot 10	Magnet Set	45	47	67	Ø6.5	Plate+Plastic	113 gr
2.2.004.0001	6 - 8 - 10	Magnet Set	28	20	4	Ø6.5	Plate	14.5 gr
2.2.004.0000.00	-	Magnet	40	28	20	-	Alnico	31 gr

Using Area

Auxiliary elements used to keep cabin and cabinet doors closed. Magnets are connected to profile slots and keep the caps closed after being shut.

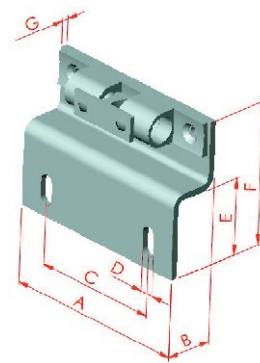
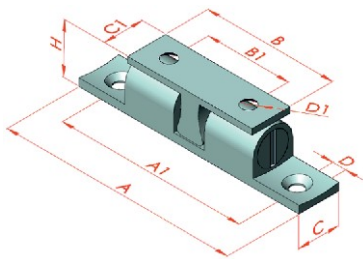
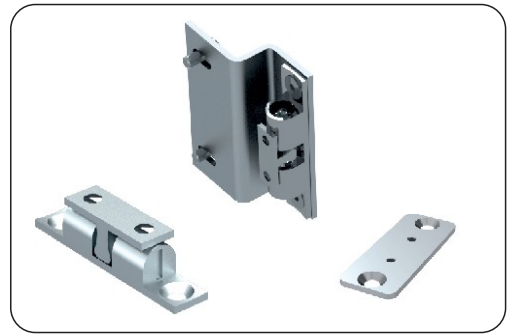
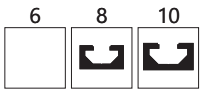

Code	Name of the product	A	A1	B	B1	C	C1	D	D1	H	E	F	G	RENK	Material	Weight
2.2.004.08.000	Tension Ball Catch Latch 30-25-20 Nickel Plated 42mm	42	34	22,8	15,3	8	7,8	3,5	3,7	10,5	-	-	-	NICKEL	BRASS	13 gr
2.2.004.10.000	Tension Ball Catch Latch 45-40-35 Nickel Plated 60mm	58	46,6	32,8	22	10,5	10	4,2	4,2	13	-	-	-	NICKEL	BRASS	29 gr
2.2.004.08.000.10	Tension Ball Catch Latch Kit (Lock + Connecting Plate) 42mm	43	33	15	-	30	-	4,5	-	-	21	45,5	2	NICKEL	BRASS	36 gr
2.2.004.10.000.10	Tension Ball Catch Latch Kit (Lock + Connecting Plate) 60mm	60	46,6	17	-	41	-	4,5	-	-	28	62	2	NICKEL	BRASS	68 gr

Using Area

Lock mechanism used for stabilizing the opening/closing doors in cabin assembly applications.



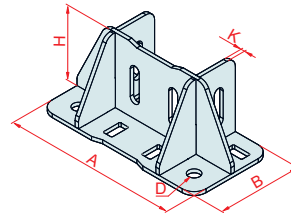
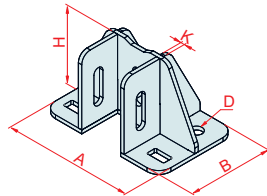
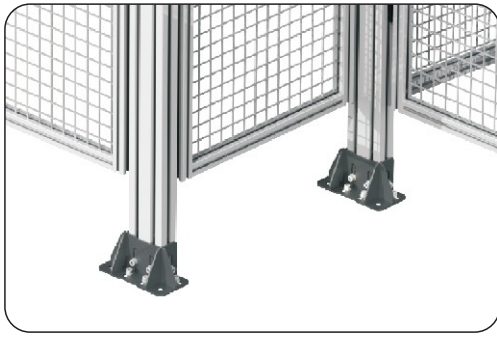

Code	Prf Size	Name of the product	A	B	D	H	K	Material	Weight
2.2.002.040040.00.10	40x40	Feet Ground Fastener	130	89	13	66	4	HRP	740 gr
2.2.002.040080.00.10	40x80	Feet Ground Fastener	170	86	13	66	4	HRP	860 gr
2.2.002.045045.00.10	45x45	Feet Ground Fastener	135	89	13	80	4	HRP	862 gr
2.2.002.045090.00.10	45x90	Feet Ground Fastener	180	89	13	80	4	HRP	972 gr

Using Area

Used where it is necessary to fix frame and cabin feet to the ground. Very strong metal fasteners with tie pieces on two axes.

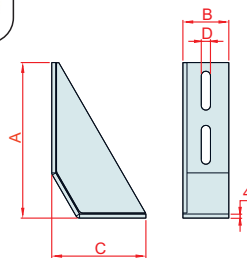
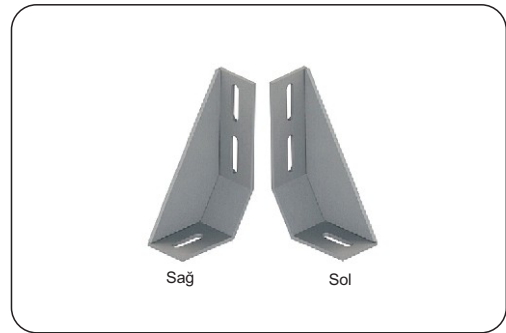

Code	Name of the product	A	B	C	D	Material	Weight
2.2.002.00.00	Feet Fixing Piece	153	45	92	9	HRP	488.5 gr
2.2.002.00.01	Feet Fixing Piece	153	45	92	9	HRP	488.5 gr

Using Area

Used when the feet need to be fixed on the ground during assembly. Right and left options are available. Areas of use include conveyor frames, table legs, machine frames.

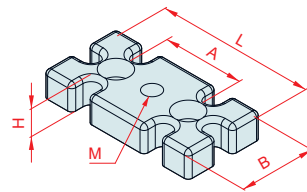
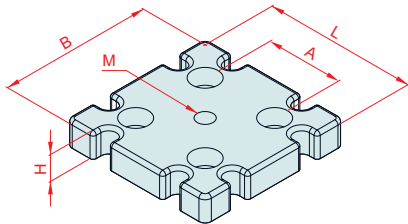
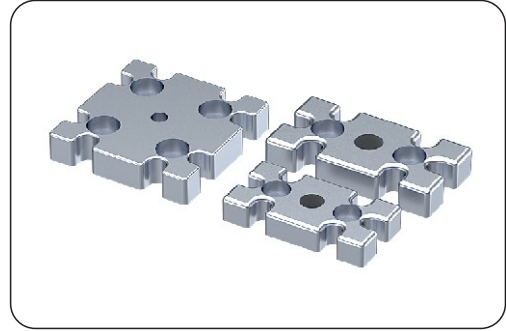

Code	Prf Size	Name of the product	M	A	L	B	H	Material	Weight
2.2.005.3060.06	30x30 30x60	Foot Fastener	M6	30	60	30	16	Etial 150 Alm.	45 gr
2.2.005.3060.08	30x30 30x60	Foot Fastener	M8	30	60	30	16	Etial 150 Alm.	45 gr
2.2.005.4080.10	40x80 45x45	Foot Fastener	M10	40	80	40	15	Etial 150 Alm.	76 gr
2.2.005.4080.12	40x80 45x45	Foot Fastener	M12	40	80	40	15	Etial 150 Alm.	74.5 gr
2.2.005.4590.10	45x90	Foot Fastener	M10	45	90	45	15	Etial 150 Alm.	101 gr
2.2.005.4590.12	45x90	Foot Fastener	M12	45	90	45	15	Etial 150 Alm.	100 gr
2.2.005.050100.10	50x100	Foot Fastener	M10	45	90	45	15	Etial 150 Alm.	95.5 gr
2.2.005.6060.10	60x60	Foot Fastener	M10	50	100	60	15	Etial 150 Alm.	180 gr
2.2.005.6060.10	60x60	Foot Fastener	M10	30	60	60	15	Etial 150 Alm.	119 gr
2.2.005.6060.12	60x60	Foot Fastener	M12	30	60	60	15	Etial 150 Alm.	119 gr
2.2.005.8080.10	80x80	Foot Fastener	M10	40	80	80	15	Etial 150 Alm.	218.5 gr
2.2.005.8080.12	80x80	Foot Fastener	M12	40	80	80	15	Etial 150 Alm.	217.5 gr
2.2.005.9090.12	90x90	Foot Fastener	M12	45	90	90	15	Etial 150 Alm.	201 gr
2.2.005.9090.16	90x90	Foot Fastener	M16	45	90	90	15	Etial 150 Alm.	195 gr
2.2.005.100100.10	100x100	Foot Fastener	M10	50	100	100	15	Etial 150 Alm.	370 gr

**Using Area**

Enables sound assembly of jointed feet and wheels on the construction. Various sizes, designed according to profile section, are available.

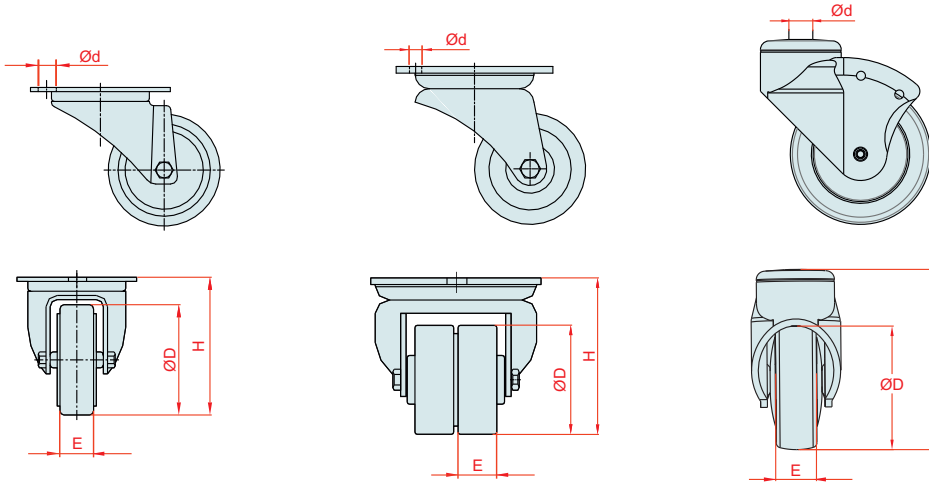
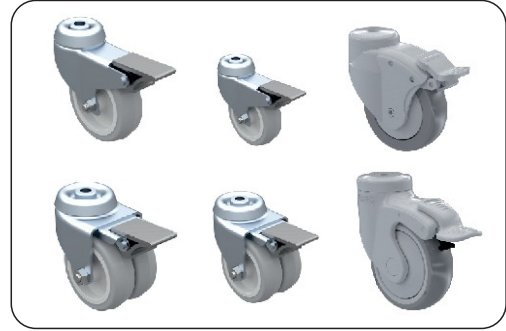

Code	Name of the product	E	Ø D	Ø d	H	Yükleme Kap.	Material	Weight
2.3.004.050.01	Ø50 Single Wheel	20	50	10	70	35 kg	Polyamid	204 gr
2.3.004.050.02	Ø50 Double Wheel	20	50	10	70	55 kg	Polyamid	277 gr
2.3.004.075.01	Ø75 Single Wheel	25	75	10	100	60 kg	Polyamid	298 gr
2.3.004.075.02	Ø75 Double Wheel	25	75	10	100	80 kg	Polyamid	538 gr
2.3.004.100.01	Ø100 Single Wheel	30	100	12	130	140 kg	Polyamid	719 gr
<b>NEW</b> 2.3.004.080.02	Ø80 Plastic Wheel With Brake	30	100	12	130	140 kg	Polyamid	719 gr
<b>NEW</b> 2.3.004.080.03	Ø80 Plastic Wheel Without Brake	25	75	10	100	80 kg	Polyamid	538 gr
<b>NEW</b> 2.3.004.100.02	Ø100 Plastic Wheel With Brake	30	100	12	150	140 kg	Polyamid	719 gr
<b>NEW</b> 2.3.004.100.03	Ø100 Plastic Wheel Without Brake	36	100	11	150	140 kg	Polyamid	450 gr

Using Area

Units, which are required not to be immobile, can be moved by means of wheels of various diameters. Can be fixed anywhere thanks to lock mechanism. Areas of use include trolleys, carriages and conveyor feet.

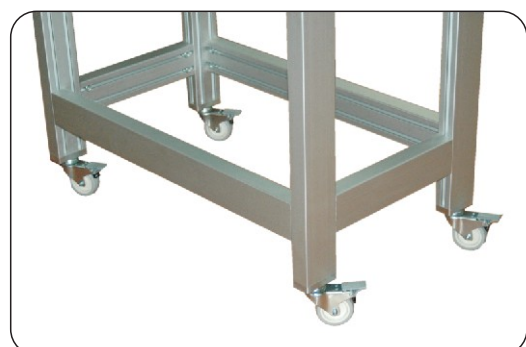
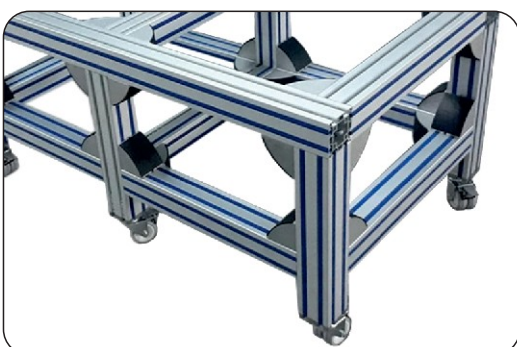

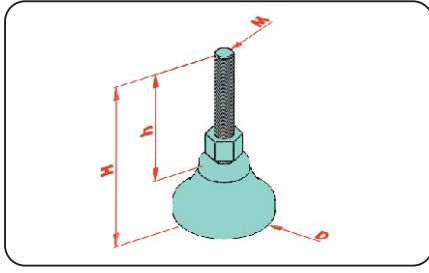

Code	Name of the product	D	M	H	h	Material	Weight	Taş. Yük
2.3.002.0650	M6 Plastic Feet	Ø 50	M6	63	30	Plastic	32 gr	39 kg
2.3.002.0845	M8 Plastic Feet	Ø 50	M8	82	50	Plastic	44 gr	49.5 kg
2.3.002.1050	M10 Plastic Feet	Ø 60	M10	87	50	Plastic	86 gr	114 kg
2.3.002.10100	M10 Plastic Feet	Ø 60	M10	137	99	Plastic	111 gr	114 kg
2.3.002.1250	M12 Plastic Feet	Ø 60	M12	80	50	Plastic	101 gr	152kg
2.3.002.1650	M16 Plastic Feet	Ø 108	M16	145	99	Plastic	283 gr	325.5 kg

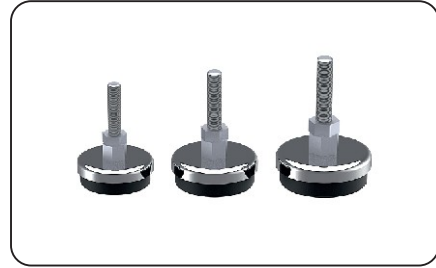
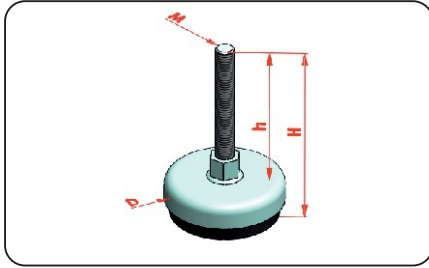

Code	Name of the product	D	M	H	h	Material	Weight	Taş. Yük
2.3.003.060	M10 Chromium-coated Stand	Ø 60	M10	103	70	Crom - Steel	188 gr	190 kg
2.3.003.080	M12 Chromium-coated Stand	Ø 80	M12	146	100	Crom - Steel	479 gr	489 kg
2.3.003.120	M16 Chromium-coated Stand	Ø 120	M16	150	100	Crom - Steel	1.081 gr	1.150 kg

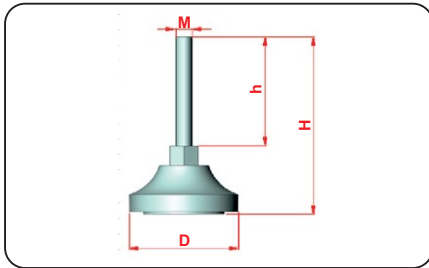

Code	Name of the product	D	M	H	h	Material	Weight	Taş. Yük
2.3.001.0650	Metal Foot M6x45	Ø 40	M6	80	50	Otomat	150 gr	130 kg
2.3.001.0850	Metal Foot M8x50	Ø 50	M8	80	50	Otomat	250 gr	180 kg

**Using Area**

This foot type is used for ground contact of medium-load profile constructions. Jointed structure ensures easy adaptation to the floor. Areas of use include work and assembly benches and test devices.



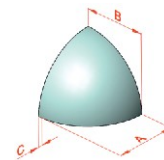
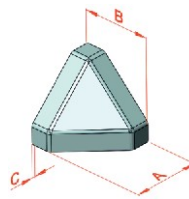
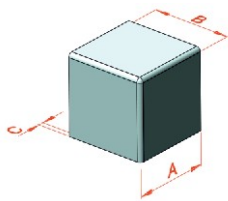
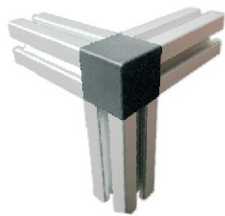
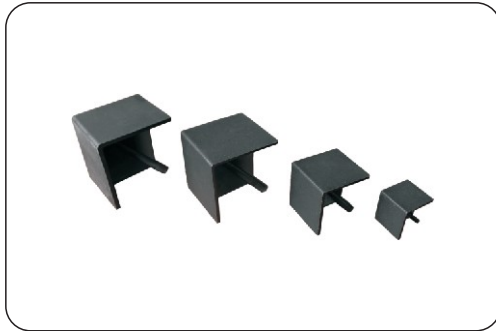

Code	Name of the product	A	B	C	Material	Weight
2.3.001.2020.07	20x20 Square Cap	20	20	2	Plastic	3 gr
2.3.001.3030.07	30x30 Square Cap	30	30	3	Plastic	8 gr
2.3.001.4040.07	40x40 Square Cap	40	40	3	Plastic	13.5 gr
2.3.001.4545.07	45x45 Square Cap	45	45	3	Plastic	22 gr
2.3.001.4040.08	Triangular Corner Bracket Cap	40	40	3	Plastic	7 gr

Code	Name of the product	A	B	C	Material	Weight
2.3.001.2020.05	Radius Corner Bracket Cap	20	20	3	Plastic	2 gr
2.3.001.3030.05	Radius Corner Bracket Cap	30	30	3	Plastic	4 gr
2.3.001.4545.05	Radius Corner Bracket Cap	45	45	3	Plastic	14 gr

Using Area

Used for covering corner brackets in construction after assembly. Corner bracket covers ensure hygiene and stylish.

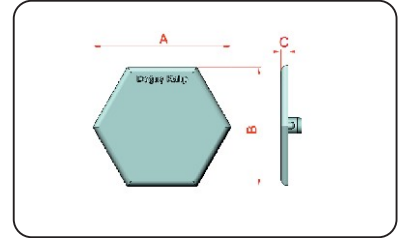
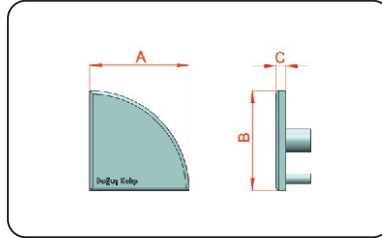
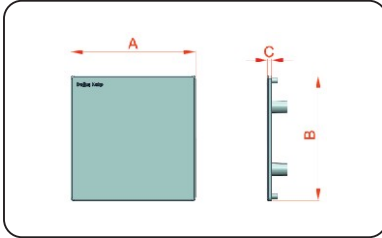
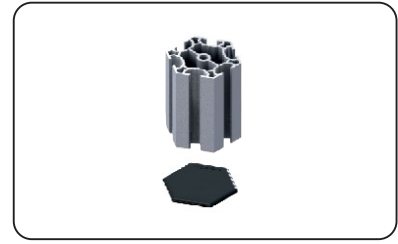
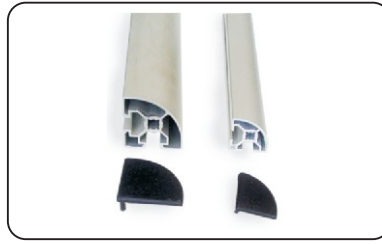
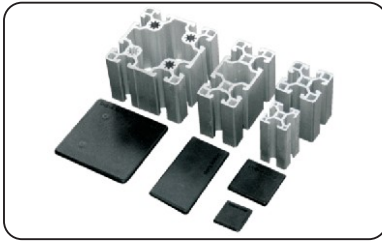

Code	Name of the product	A	B	C	Renk	Material	Weight
2.3.001.2020.01	20x20 Profile Cap	20	20	2	●	PA. 6	1 gr
2.3.001.2040.01	20x40 Profile Cap	20	40	3	●	PA. 6	2 gr
2.3.001.2080.01	20x80 Profile Cap	20	80	3	●	PA. 6	4 gr
2.3.001.2525.01	25x25 Profile Cap	25	25	3	●	PA. 6	1.5 gr
2.3.001.3030.01	30x30 Profile Cap	30	30	3	●●	PA. 6	3.5 gr
<b>NEW</b> 2.3.001.3045.01	30x45 Profile Cover Rated	45	42	3	●	PA. 6	2.8 gr
2.3.001.3535.02	35x35 Heavy Profile Cap	35	35	3.3	●	PA. 6	4 gr
2.3.001.3535.01	35x35 Heavy Profile Cap	35	35	3.3	●	PA. 6	4.5 gr
2.3.001.3060.01	30x60 Profile Cap	30	60	3	●●	PA. 6	7 gr
2.3.001.3090.01	30x90 Profile Cap	30	90	3.3	●●	PA. 6	7.5 gr
2.3.001.4040.01	40x40 Profile Cap(K10)	40	40	3.3	●●	PA. 6	5.5 gr
2.3.001.4040.02	40x40 Profile Cap (K8)	40	40	3.3	●	PA. 6	5.5 gr
<b>NEW</b> 2.3.001.4045.01	40x40 Profile Cover Rated	40	40	3.3	●	PA. 6	3.4 gr
2.3.001.4080.02	40x80 Profile Cap (K8)	40	80	3.3	●	PA. 6	8.88 gr
2.3.001.4080.01	40x80 Profile Cap(K10)	40	80	3.3	●●	PA. 6	9.5 gr
2.3.001.4545.01	45x45 Profile Cap	45	45	3.6	●●	PA. 6	8 gr
2.3.001.4545.02	45x45 Profile Cap S.Light	45	45	3.6	●	PA. 6	6.44 gr
2.3.001.4560.01	45x60 Profile Cap	45	60	3.6	●	PA. 6	9.5 gr
2.3.001.4590.01	45x90 Profile Cap	45	90	3.6	●●	PA. 6	15.5 gr
<b>NEW</b> 2.3.001.45135.01	45x135 Profile Cap	45	135	3.6	●●	PA. 6	19 gr
2.3.001.5050.01	50x50 Profile Cap	50	50	3.6	●●	PA. 6	8 gr
2.3.001.50100.01	50x100 Profile Cap	50	100	3.6	●●	PA. 6	17 gr
2.3.001.6060.01	60x60 Profile Cap	60	60	3.6	●	PA. 6	11.5 gr
2.3.001.6060.02	60x60 Profile Cap with Double Slot	60	60	3.6	●	PA. 6	12.5 gr
<b>NEW</b> 2.3.001.6090.01	60x90 Profile Cap	90	60	3.6	●	PA. 6	18.33 gr
<b>NEW</b> 2.3.001.8080.03	80x80 Profile Cap (K8)	80	80	3.6	●	PA. 6	21.6 gr
2.3.001.8080.01	80x80 Profile Cap (K10)	80	80	3.6	●	PA. 6	19.5 gr
2.3.001.9090.01	90x90 Profile Cap	90	90	3.6	●	PA. 6	31 gr
2.3.001.2020.03	20x20 Radius Profile Capı	20	20	3	●	PA. 6	1 gr
2.3.001.3030.03	30x30 Radius Profile Cap	30	30	3	●	PA. 6	2.5 gr
2.3.001.4545.03	45x45 Radius Profile Cap	45	45	3	●	PA. 6	7 gr
2.3.001.23127.01	23x127 Profile Cap	23	126.8	4.2	●	PA. 6	18.5 gr
<b>NEW</b> 2.3.001.0030.01	30x30 Stand Profile Cap	60	52	3	●	PA. 6	5.67 gr

Not: Gray Cap Code 2.3.001.xxxx.11

### Using Area

Used for covering profile butts that are left open after assembly on profile constructions. Prevents damage on profile ends and different color options enable stylish view.

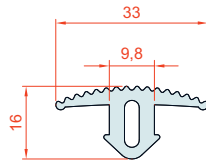
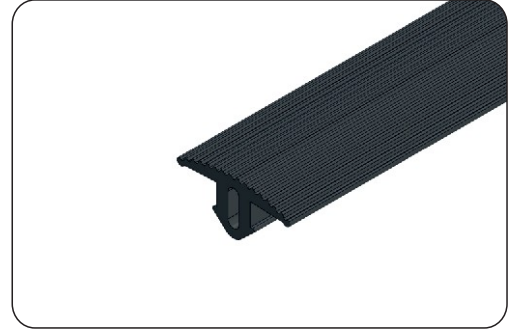
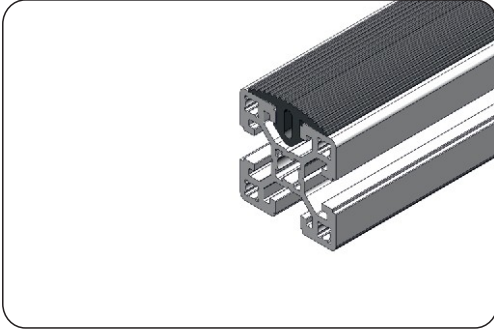
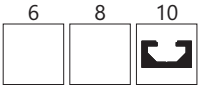

Code	Name of the product	Malzeme	A	B	Slot	Renk	Weight
2.3.007.10.00.01	Profile Guard Single-Surface - Slot 10	Rubber	33	16	K10	Black	0,21 Kg/m

**Using Area**

Designed to protect single surface of profile in Slot 10 series. Prevents profile from crushing and scratching against hard impacts. Areas of use include trolleys and maintenance constructions.

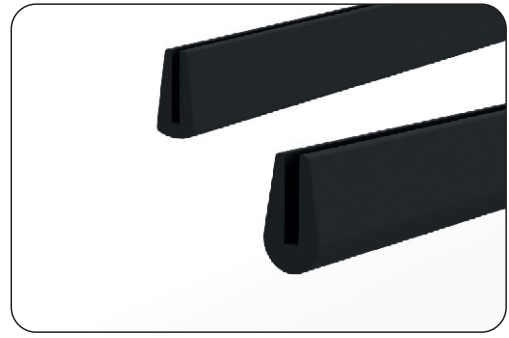
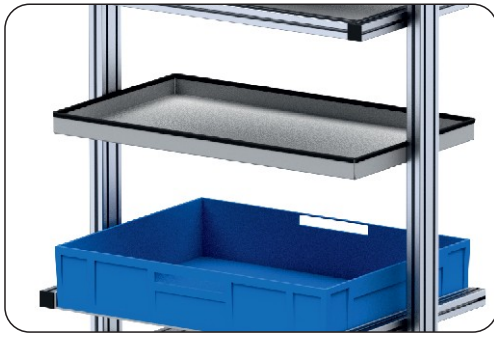

Name of the product: Sac Fitili 1-1,5 mm  
Code: 2.3.006.00.01.00

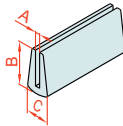

Name of the product: Sac Fitili 2-2,5 mm  
Code: 2.3.006.00.02.00

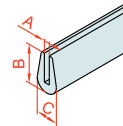

Code	Name of the product	A	B	C	Material	Weight(gr)
2.3.006.00.01.00	Sheet Roving 1-1,5 mm	1	9	4,8	Rubber	38,38
2.3.006.00.02.00	Sheet Roving 2-2,5 mm	1.8	12.2	7	Rubber	76

Using Area

It is produced in order to cover the exposed parts of the metal sheets within the scope of occupational safety in applications such as conveyor , chassis , cabin etc. gh slots and prevents prop up and contamination of slots.

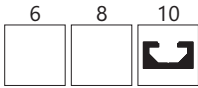

Sac Fitili Hortumlu K08  
Code: 2.3.006.08.00.00

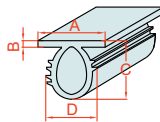

Sac Fitili Hortumlu K10  
Code: 2.3.006.10.00.00

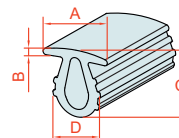

Code	Name of the product	A	B	C	D	Renk	Malzeme	Weight
2.3.006.08.00.00	Hose Glass Seals - Slot 8	13,35	1,3	11,65	10,2	Black	PVC	0,063 Kg/m
2.3.006.10.00.00	Hose Glass Seals - Slot 10	15	1,53	14	10	Black	PVC	0,106 Kg/m

Using Area

Made with sigma profiles with a channel size of 10mm In the profile channel of the sheet in cabin applications provides fixation.



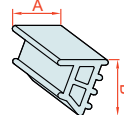
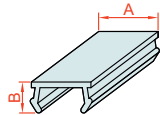
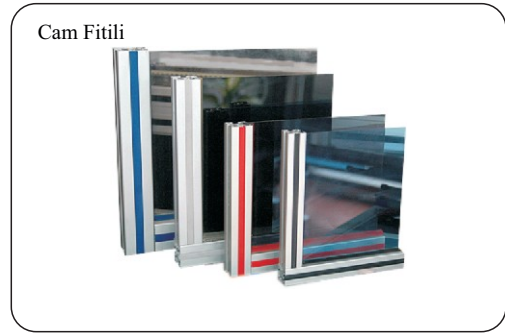
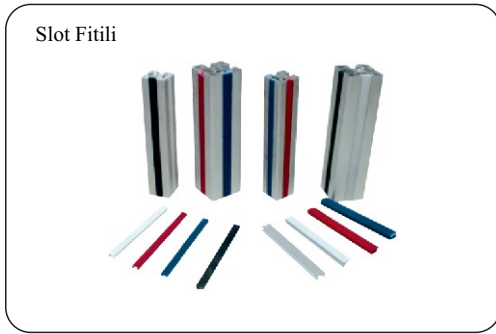

Code		Name of the product	Renk	A	B	Material
2.3.005.06	Slot 6	Slot Seal		7.3	3.8	Plastic
2.3.005.08	Slot 8	Slot Seal		8.9	4.3	Plastic
2.3.005.10	Slot 10	Slot Seal		11.7	8.1	Plastic
2.3.005.08.01	Slot 8	Slot Seals		8.9	4.3	Rubber
2.3.005.10.01	Slot 10	Slot Seals		11.7	8.1	Rubber

Note:\* Please enter the codes below instead of xx for color selection.

- Black Wick Code 01 instead of xx
- Gray Wick Code 02 instead of xx
- Red Wick Code 03 instead of xx
- Blue Wick Code 04 instead of xx

Code		Name of the product	Renk	A	B	Material
2.3.006.06	Slot 6	Glass Seals		7	7	Plastic
2.3.006.08	Slot 8	Glass Seals		8.5	11.3	Plastic
2.3.006.10	Slot 10	Glass Seals		11	12.1	Plastic

Note:\* Please enter the codes below instead of xx for color selection.

- Black Wick Code 01 instead of xx
- Gray Wick Code 02 instead of xx
- Red Wick Code 03 instead of xx
- Blue Wick Code 04 instead of xx

Using Area

Glass Seal Enables fixing plexiglass to profile slot in cabin applications with sigma profiles with a slot. Available in black, blue, red or transpent Canal Seal Mounted on slots that are left out in applications with a sigma profile with slot size of 8 mm in order to ensure stylish view. Besides, it ensures closing cables passing through slots and prevents prop up and contamination of slots.



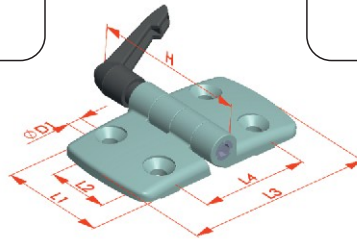
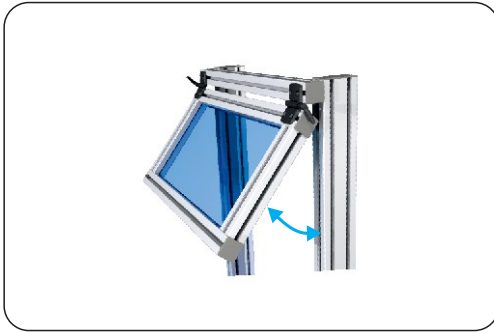

Code	Prf Size	Name of the product	H	L1	L2	L3	L4	D1	Material	Weight
2.2.003.2525.03	25x25	Locking Hinge	72	48	28	52	30	6,6	PA6 Siyah	46 gr
2.2.003.3030.03	30x30	Locking Hinge	72	48	28	59	35	6,6	PA6 Siyah	48 gr
2.2.003.4545.03	45x45	Locking Hinge	72	48	28	87	50	6,6	PA6 Siyah	60,5 gr

Using Area

A hinge type preferable for anchoring moving caps at required angle. Clamping arms ensure required level of stabilization.

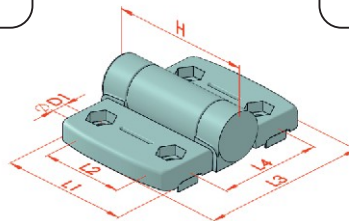

Code	Prf Size	Name of the product	H	L1	L2	L3	L4	D1	Material	Weight
2.2.003.4545.04	45x45	Covered Hinge	72	48	28	84	50	6,6	PA6 Siyah	41 gr

Using Area

These hinges, used on profiles with slot size of 10 mm, comprise plastic caps that conceal mounting bolts. Caps mounted on outer surface ensures stylish view.

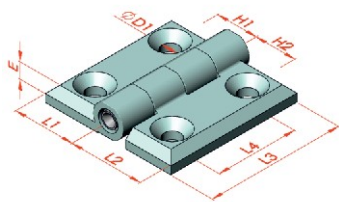

Metal Hinge

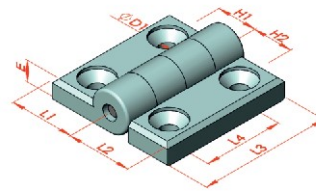

Plastic Hinge

Code	Prf Size	Name of the product	Prf	H1	H2	L1	L2	L3	L4	D1	Material	Weight
2.2.003.2020	20x20	Hinge (Thin Series)	5	10.25	10.25	18.35	18.35	35	19	6	PA 6 Black	8.5 gr
2.2.003.2025	20x25	Hinge (Thin Series)	5	10.25	12.75	18.35	23.35	35	19	6	PA 6 Black	10 gr
2.2.003.2525	25x25	Hinge (Thin Series)	5	12.75	12.75	23.35	23.35	35	19	6	PA 6 Black	11 gr
2.2.003.2030	20x30	Hinge (Thin Series)	5	10.25	15.25	18.35	23.35	35	19	6	PA 6 Black	9.5 gr
2.2.003.2530	25x30	Hinge (Thin Series)	5	15.25	12.75	23.35	23.35	35	19	6	PA 6 Black	10 gr
2.2.003.3030.5	30x30	Hinge (Thin Series)	5	15.25	15.25	23.35	23.35	35	19	6	PA 6 Black	10.5 gr
2.2.003.3030	30x30	Hinge	8	15	15	25	25	50	30	6.5	PA 6 Black	29.5 gr
2.2.003.3535	35x35	Hinge	8	17.5	17.5	32	32	50	30	6.5	PA 6 Black	34 gr
2.2.003.4530	45x30	Hinge	8	22.75	15	25	32	50	30	6.5	PA 6 Black	31 gr
2.2.003.4535	45x35/40x40	Hinge	8	22.75	17.5	32	32	50	30	6.5	PA 6 Black	33 gr
2.2.003.4545	45x45	Hinge	8	22.75	22.75	32	32	50	30	6.5	PA 6 Black	34 gr
2.2.003.2525.01	25x25	Metal Hinge	5	12.5	12.5	20	20	40	25	5.5	Zinc	44 gr
2.2.003.3030.01	30x30	Metal Hinge	6	15.5	15.5	25	25	50	30	6.5	Zinc	83 gr
2.2.003.4040.01	40x40	Metal Hinge	6	20,4	20,4	32,5	32,5	50	30	6.5	Zinc	42 gr
2.2.003.4545.01	45x45	Metal Hinge	6	22,9	22,9	35	35	50	30	6.5	Zinc	42 gr

Using Area

The hinges, which enable opening and closing cabin and cabinet doors, are manufactured in line with slot axis size of profiles to be mounted.

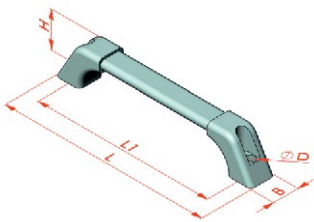

Aluminum Pipe Handle Oval

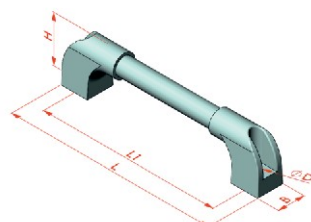

Aluminum Pipe Handle

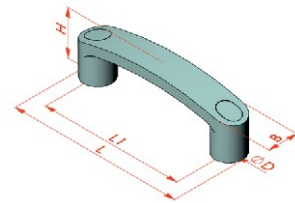

Plastic Handle with Red Stopper

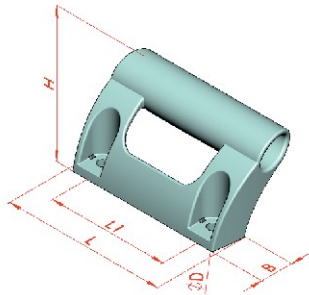

Plastic Sliding Handle

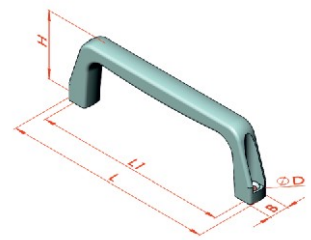

Plastic Handle Thin

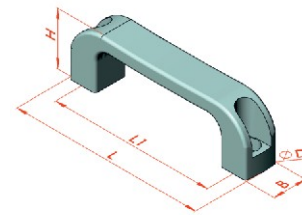

Plastic Handle

Code	Name of the product	H	L	L1	B	D	Material	Weight
2.3.008.00	Plastic Handle	39,4	136	115,5	24	Ø13,5	Plastic	44,5 gr
2.3.008.03	Plastic Handle thin	41	131	119,5	12	Ø5	Plastic	25 gr
2.3.008.02.00	Plastic Sliding Handle	65,1	125,6	100	27	Ø8,5	Plastic	110 gr
2.3.008.01.05	Aluminum Tube Handle Oval	42	230	198	29	Ø11,5	Aluminum	70 gr
2.3.008.01.04	Aluminum Tube Handle Oval	47	233	200	38	Ø8	Aluminum	88 gr
2.3.008.01	Aluminum Tube Handle	54	230	198	30	Ø6,4	Aluminum	81 gr
2.3.008.01.03	Aluminum Tube Handle	68	236	200	36	Ø10	Aluminum	103 gr
2.3.008.00.04	Plastic Handle Red Stopper	40	144,2	116	24,2	Ø28,2	Plastic	164,4 gr

Using Area

This is a connection accessory that provides holding urface for opening and closing of movable parts.Ensures stylish view together with other accessories applied on constructions.

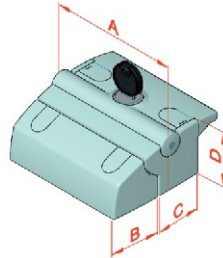
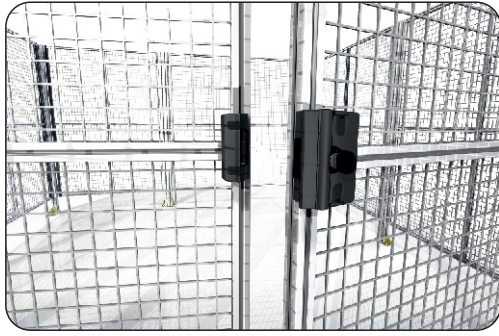

Code	Name of the product	A	B	C	D	Material	Weight
2.2.014.01.000	Security Lock	80	40	35	31	Etial 150 Alm	243 gr

Using Area

It used for the protection and safety systems a key mechanism used.

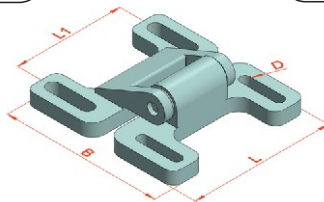
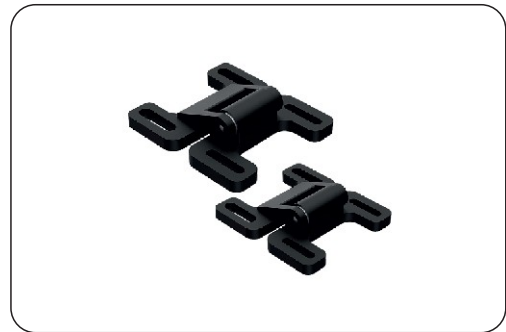
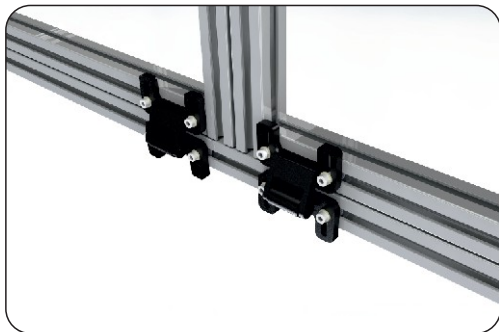

Code	Name of the product	Prof.Ebat	L	L1	B	D	Material	Weight
2.2.004.2520	Plastic Ball Lock	20 - 25 - 30	53	40	55	Ø5	Plastic	25 gr
2.2.004.4545	Plastic Ball Lock	35 - 40 - 45	74	57	77	Ø5.5	Plastic	40 gr

Using Area

Ball lock It's used to prevent opening windows on machine cabinets which has high vibration.

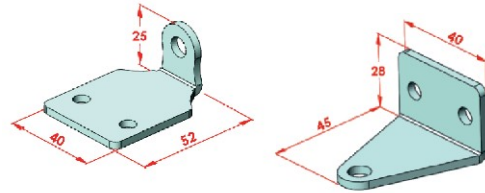
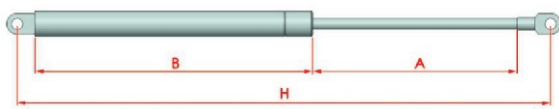
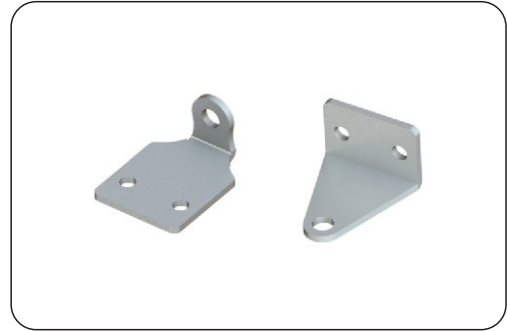

Code	Name of the product	A	C	H Min. Max	Material	Weight
2.3.010.150300	Dampers	150	195	233 - 383	Steel	205 gr
2.3.010.105150	Gas Spring (Stroke 105mm) F150N	105	145	188 - 293	Steel	159 gr
2.3.010.085085	Gas Spring (Stroke 85mm) F85N	85	130	168 - 253	Steel	148 gr
2.3.010.00	Gas Spring Connecting Piece	45	40	28	Steel	48 gr

**Using Area**

Components that ensure fixing cabin sashes and cabinet doors at desired angle. Easily mountable to profile slots thanks to genuine connection plate. Depending on intended use, dampers of various pressure can be selected.

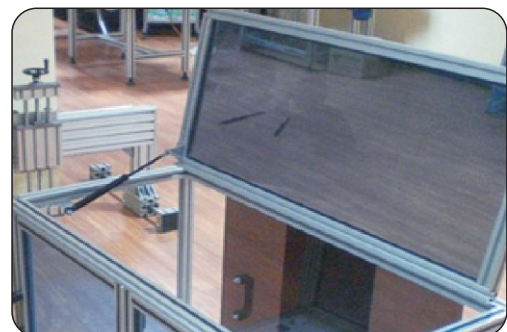

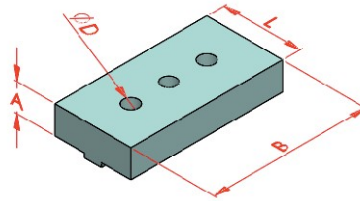
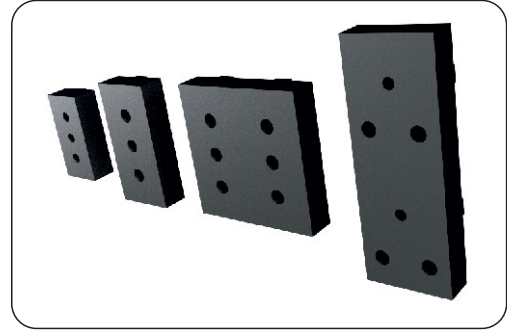
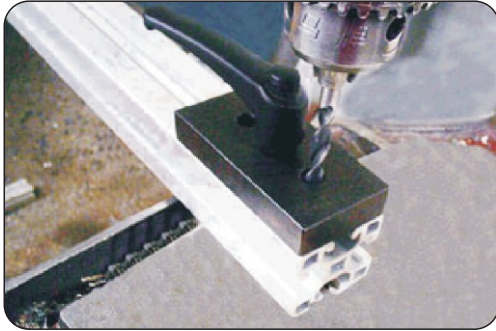

Code	Name of the product	Kullanım Alanı	A	B	L	ØD	Material	Weight
2.3.007.2020	Drilling Apparatus	20x20	20	40	20	Ø5.5	Steel 50-55 Hrc	108 gr
2.3.007.2525	Drilling Apparatus	25x25	20	50	25	Ø5.5	Steel 50-55 Hrc	169 gr
2.3.007.3030	Drilling Apparatus	30x30	18.5	60	30	Ø7	Steel 50-55 Hrc	222 gr
2.3.007.3535.01	Drilling Apparatus	35x35 (L)	19	70	35	Ø7	Steel 50-55 Hrc	328 gr
2.3.007.3535.02	Drilling Apparatus	35x35 (A)	19	70	35	Ø9	Steel 50-55 Hrc	356 gr
2.3.007.4040	Drilling Apparatus	40x40-40x80 (K10)	19,5	80	40	Ø9	Steel 50-55 Hrc	411 gr
2.3.007.4040.01	Drilling Apparatus	40x40-40x80 (K8)	18.5	80	40	Ø7	Steel 50-55 Hrc	417 gr
2.3.007.4545	Drilling Apparatus	45x45-45x90	19	90	45	Ø9	Steel 50-55 Hrc	508 gr
2.3.007.5050	Drilling Apparatus	50x50-50x100 (A)	19,5	100	50	Ø9	Steel 50-55 Hrc	600 gr
2.3.007.3060	Drilling Apparatus	30x60-60x60	19	60	60	Ø7	Steel 50-55 Hrc	460 gr
2.3.007.8080	Drilling Apparatus	40x80-80x80	20	80	80	Ø8,3	Steel 50-55 Hrc	795 gr
2.3.007.9090	Drilling Apparatus	45x90-90x90	19	90	90	Ø9	Steel 50-55 Hrc	1026 gr
2.3.007.23127	Drilling Apparatus	23x127	19	127	46	Ø8	Steel 50-55 Hrc	745 gr
2.3.007.2375	Drilling Apparatus	23x75	14	75	20	Ø6,5	Steel 50-55 Hrc	139 gr



Using Area

Steel components especially produced to bore mounting holes on profile slots. Single and double slot series of various size are available.

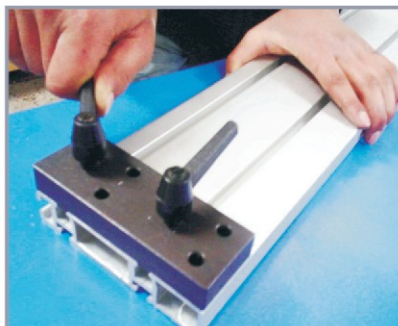
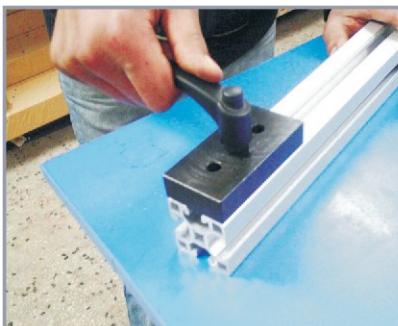

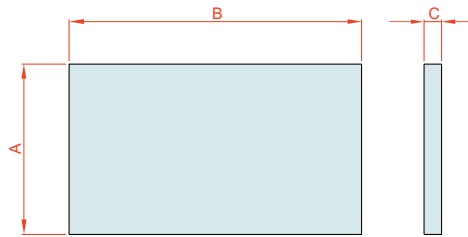

Code	Name of the product	A	B	C	Material	Weight
2.3.009.0003.01	Plexi Acrylic 3 Mm	1350	2000	3	Pleksiglas	3,57 m <sup>2</sup> /Kg
2.3.009.0004.01	Plexi Acrylic 4 mm	1350	2000	4	Pleksiglas	4,76 m <sup>2</sup> /Kg
2.3.009.0005.01	Plexi Acrylic 5 mm	1350	2000	5	Pleksiglas	5,95 m <sup>2</sup> /Kg
2.3.009.0006.01	Plexi Acrylic 6 mm	1350	2000	6	Pleksiglas	7,14 m <sup>2</sup> /Kg
2.3.009.0008.01	Plexi Acrylic 8 mm	1350	2000	8	Pleksiglas	9,52 m <sup>2</sup> /Kg
2.3.009.0010.01	Plexi Acrylic 10 mm	1350	2000	10	Pleksiglas	11,90 m <sup>2</sup> /Kg

**Note:\*** Please enter the codes below instead of xx for color selection.

- Acrylic Transparent Plexiglass Code 01 instead of xx
- Acrylic Smoked Plexiglass Codeu 05 instead of xx
- Acrylic Blue Plexiglass Codeu 06 instead of xx
- Acrylic Black Plexiglass Codeu 08 instead of xx

### Using Area

Plexiglasses, which are applied for zone covering on any kind of construction, can be preferred in various colors and thickness depending on intended place of use. Contribute to system hygiene and appearance. Produced in various color options.



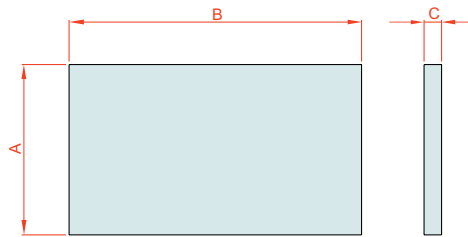
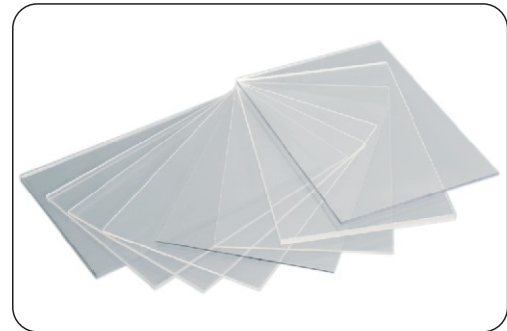

Code	Name of the product	A	B	C	Material	Weight
2.3.012.0003.001	Solid Polycarbon Transparent 3 mm	2050	3050	3	S.polikarbon	3,6 m <sup>2</sup> /Kg
2.3.012.0004.001	Solid Polycarbon Transparent 4 mm	2050	3050	4	S.polikarbon	4,8 m <sup>2</sup> /Kg
2.3.012.0005.001	Solid Polycarbon Transparent 5 mm	2050	3050	5	S.polikarbon	6 m <sup>2</sup> /Kg
2.3.012.0008.001	Solid Polycarbon Transparent 8 mm	2050	3050	6	S.polikarbon	9,6 m <sup>2</sup> /Kg

Using Area

Solid polycarbonate is more resistant to breakage than plexiglass; It can be preferred in machine cabinets because it is reliable and light material that can withstand heavy conditions.

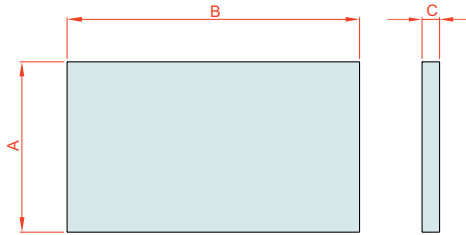



Code	Name of the product	A	B	C	Renk	Material	Weight
2.3.013.0004.001	Corrugated Polycarbonate Transparent 4 mm	2100	6000	4	● ● ●	Polikarbon	0,70 m <sup>2</sup> /Kg
2.3.013.0006.001	Corrugated Polycarbonate Transparent 6 mm	2100	6000	6	● ● ●	Polikarbon	1,00 m <sup>2</sup> /Kg
2.3.013.0008.001	Corrugated Polycarbonate Transparent 8 mm	2100	6000	8	● ● ●	Polikarbon	1,10 m <sup>2</sup> /Kg
2.3.013.0010.001	Corrugated Polycarbonate Transparent 10 mm	2100	6000	10	● ● ●	Polikarbon	1,20 m <sup>2</sup> /Kg

**Note:\*** Please enter the codes below instead of xx for color selection.  
 Transparent Corrugated Polycarbonate Code 01 instead of xx  
 Blue Corrugated Polycarbonate Code 02 instead of xx  
 Smoked Corrugated Polycarbonate Code 03 instead of xx

### Using Area

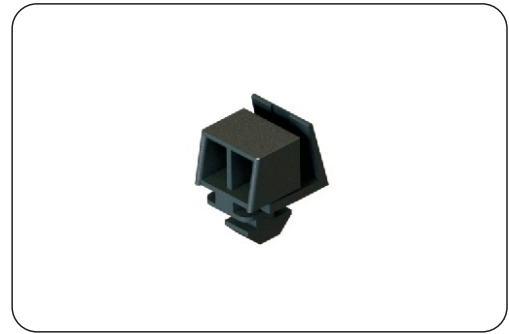
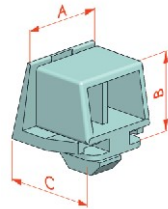
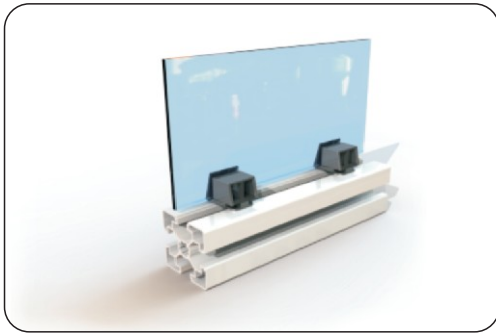
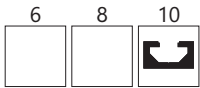
Corrugated polycarbonate which is cost-effective relative to Plexiglas; It is an ideal construction material for safety cabinets and division systems.





Code		Name of the product	A	B	C	Material	Weight
2.2.013.10.001	Slot 10	Plexi Claw Holder (K10)	22,5	21	25	NYLON6	7.46 gr

Using Area

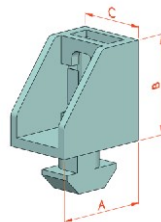
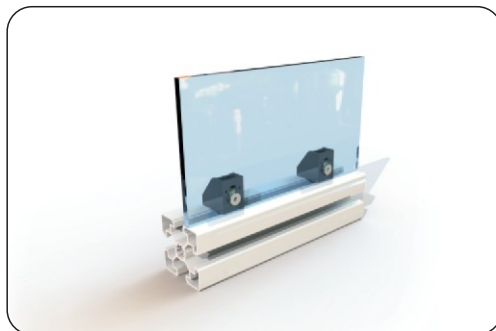
When it is not wanted to mount plexiglass into profile slot, it is possible to bond plexiglass by means of external claw holders. This enables partial dismounting if necessary.



Code		Name of the product	A	B	C	Material	Weight
 2.2.013.08.002	Slot 8	Plexi Holder with Nut (S8)M6 M6	23,5	25	18	NYLON6	4.86 gr
2.2.013.10.002	Slot 10	Plexi Holder with Nut (S10)M6	25	25	18	NYLON6	5.74 gr

Using Area

For plexiglass assembly, if it is not desired to mount them within profile slot, the plexiglass can be assembled by means of external holders with nut. Partial disassembly possible if required.

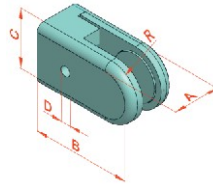
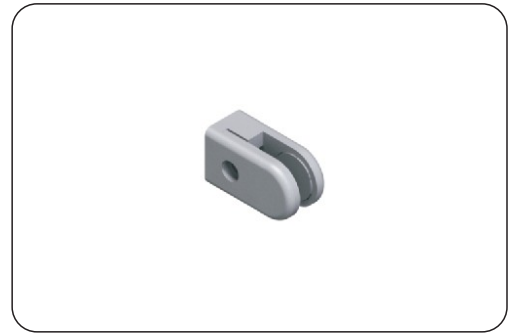
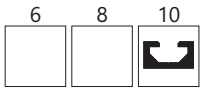

Code	Name of the product	A	B	C	D	R	Material	Weight
2.2.013.00.001	Plexi Holder Aluminum Single	20	32,5	25	4,2	12,5	Aluminum	25 gr

Using Area

Holding pieces that ensure connecting plexiglasses to profile slots on cabin systems. Are sounder and more stylish than other plastic holders.

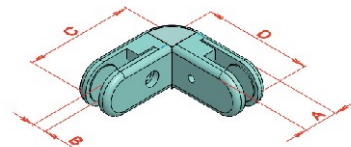
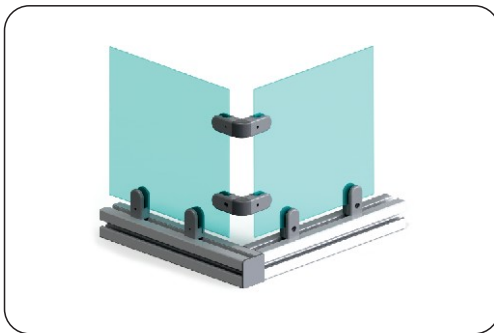

Code	Name of the product	A	B	C	D	R	Material	Weight
2.2.013.00.003	Plexi Holder Aluminum Double	20	8	65	65	-	Aluminum	82 gr

Using Area

Rotary metal pieces that mount double plexiglass of 90° in an stylish manner on cabin systems.

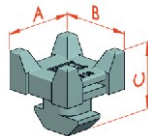
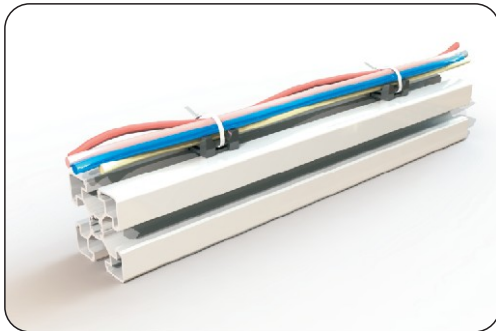

	Code		Name of the product	A	B	C	Material	Weight
	2.2.012.08.002	Slot 8	Cable Holder without Cap (S8)	22	22	19,2	Nylon 6	3.55 gr
	2.2.012.10.002	Slot 10	Cable Holder without Cap (S10)	22	22	22,3	Nylon 6	4.24 gr

Using Area

Ensures smooth connection of cables, used in automation applications, on the profiles. Thanks to the cap, the cables are restrained within apparatus without need for additional clip.

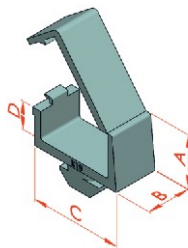
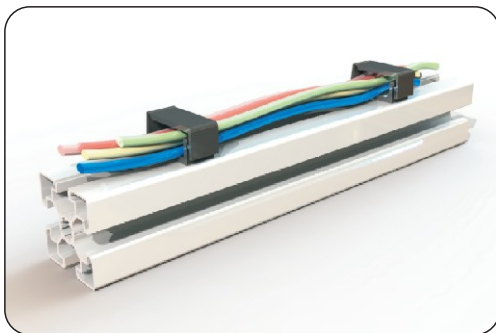

	Code		Name of the product	A	B	C	D	Material	Weight
	2.2.012.08.001	Slot 8	Capped Cable Holder (S8)	20	15	28	28	Moblen	0.80 gr
	2.2.012.10.001	Slot 10	Capped Cable Holder (S10)	20	16	34	34	Moblen	0.98 gr

Using Area

Ensures smooth connection of cables, used in automation applications, on the profiles. Thanks to the cap, the cables are restrained within apparatus without need for additional clip.

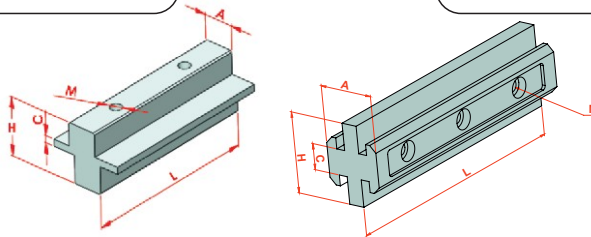
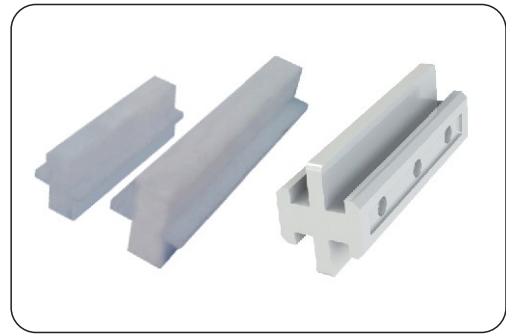
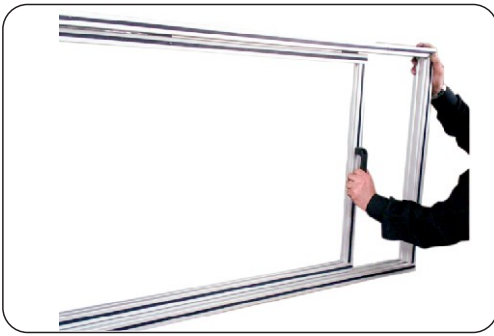

Code	Icon	Name of the product	A	C	H	L	M	Material	Weight
2.2.008.08.01	Slot 8	Slide Rail	8	2	18.7	53	M4	Delrin	8.5 gr
2.2.008.10.01	Slot 10	Slide Rail	10	2.5	20.3	60	M4	Delrin	13 gr
2.2.008.08.03	Slot 8	Slide Rail 30x30 K8 Tab	17.5	7.9	24.5	80	M3	Poletilen	26 gr
2.2.008.10.03	Slot 10	Slide Rail 45x45 K10 Tab	27.5	9.9	37.5	80	M3	Poletilen	50 gr

Using Area

Connection accessories that ensure cap movements of sliding cabins.

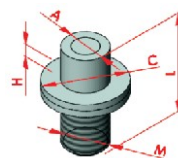

Code	Icon	Name of the product	A	C	H	L	M	Material	Weight
2.2.008.08.02	Slot 8	Accordion Pin	8	15	3	24	M8	Steel+Delrin	7 gr
2.2.008.10.02	Slot 10	Accordion Pin	10	18	3	27	M10	Steel+Delrin	12.5 gr

Using Area

Connection accessories that ensure cap movements of sliding cabins.

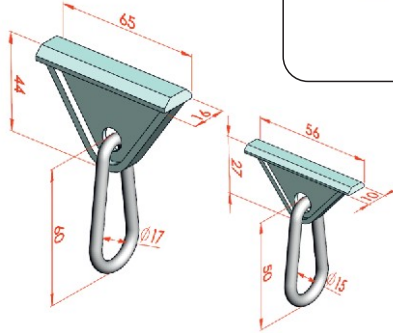

Code	Name of the product	Material	Weight
2.2.010.2025	20x25 Hanger Kit	Plastic + Steel	18 gr
2.2.010.3045	30x45 Hanger Kit	Plastic + Steel	36 gr

Using Area

The hanger which is placable into slot of profiles' chanel is used for hanging tools.

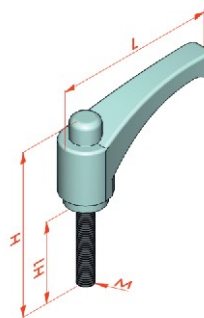
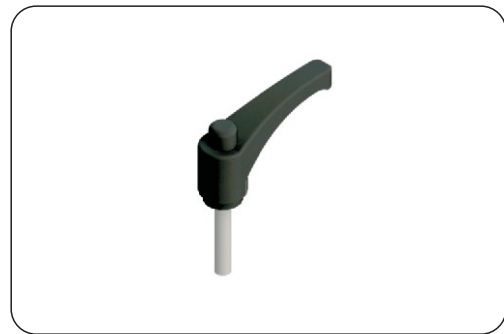
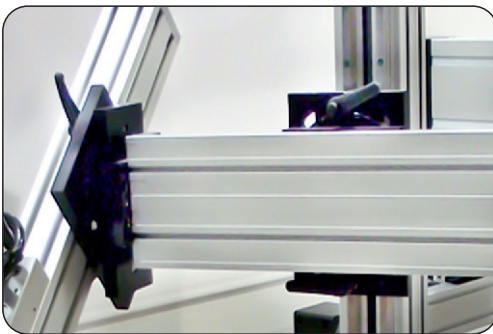

Code	Name of the product	M	L	H	h1	Material	Weight
2.2.006.06.20	Flip Lever M6x20 - Channel 6	M6	60	60	20	Plastic	22 gr
2.2.006.06.30	Flip Lever M6x30 - Channel 6	M6	60	66	30	Plastic	23 gr
2.2.006.08.40	Flip Lever M8x40 - Channel 8	M8	78	80	40	Plastic	40 gr
2.2.006.08.50	Flip Lever M8x50 - Channel 8	M8	78	92	50	Plastic	44 gr
2.2.006.10.40	Flip Lever M10x40 - Channel 10	M10	78	82	40	Plastic	55 gr
2.2.006.10.60	Flip Lever M10x60 - Channel 10	M10	78	109	60	Plastic	69 gr

Using Area

Units are used for connecting parts that should be alternatively moving and fix.

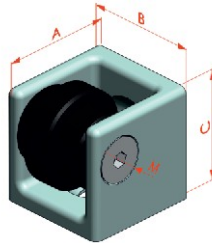

	Code	Name of the product	A	B	C	M	Material	Weight
<b>NEW</b>	2.2.014.08.3030.01	Channel Slide Set 30x30 right	30	30	30	6	Aluminyum	80 gr
<b>NEW</b>	2.2.014.08.3030.02	Channel Sliding Set 30x30 left	30	30	30	6	Aluminyum	80 gr
	2.2.014.10.4040.01	Channel Slide Set 40x40 right	40	40	40	8	Aluminyum	116 gr
	2.2.014.10.4040.02	Channel Slide Set 40x40 left	40	40	40	8	Aluminyum	116 gr
	2.2.014.10.4545.01	Channel Slide Set 45x45 right	45	45	45	8	Aluminyum	170 gr
	2.2.014.10.4545.02	Channel Slide Set 45x45 left	45	45	45	8	Aluminyum	170 gr

Using Area

The movement door ana window, which are required to be sliding on constructions, is ensured via slide sets. Manufactured in coherence with profile slots of 10 mm, the polyethylene rollers enable silent operation.

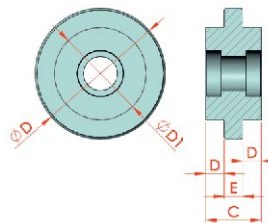





Code	Slot	Name of the product	ØD	ØD1	C	D	E	Material	Weight
2.2.015.08.010	Slot 8	Slide Wheel	47	33.5	19.3	5.8	7.8	Poliyetilen	47 gr
2.2.015.10.010	Slot 10	Slide Wheel	48	68.5	29	9.5	9.5	Poliyetilen	117 gr

Using Area

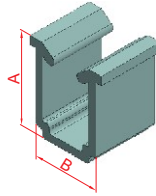
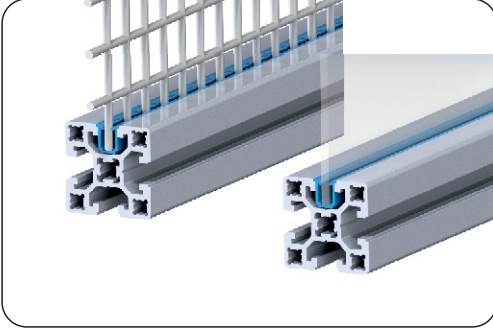
Wheels with ball bearing to ensure bedding via profile slots. Areas of use include cabin windows, sliding doors etc.





Code		Name of the product	Renk	A	B	Material
 2.3.006.08.01.01	Slot 8	In-Slot U Seal	●	9	8,2	PVC
 2.3.006.10.01.01	Slot 10	In-Slot U Seal	●	14,00	10,20	PVC

#### Using Area

Used for anchoring plexi and cage mesh in applications made of sigma profiles with slot size of 8 and 10 mm. Areas of use include protection cabins, security systems and stand applications.

- Robot Area Safety Compartments
- Machinery Area Security Compartments
- Production Line Safety Partitions

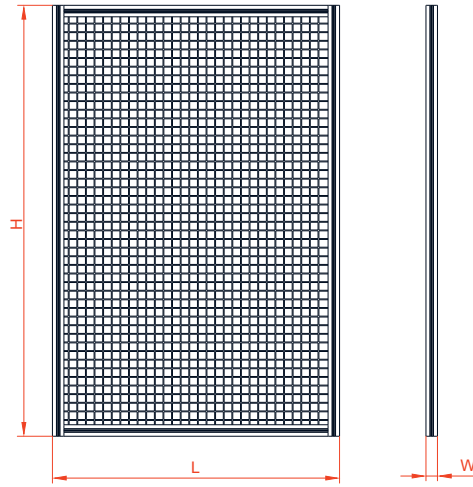
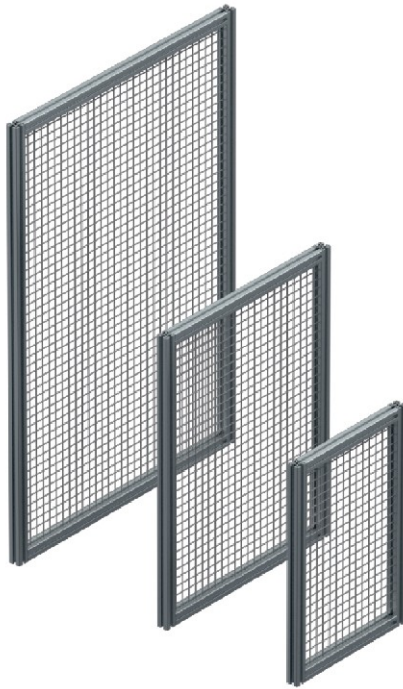

Code	Name of the product	L	H	W	Tel Kafes
17.08.01.00750.01500.0040	Security Panel	750	1500	40	30x30-3mm
17.08.01.01000.01500.0040	Security Panel	1000	1500	40	30x30-3mm
17.08.01.01250.01500.0040	Security Panel	1250	1500	40	30x30-3mm
17.08.01.00750.02000.0045	Security Panel	750	2000	45	30x30-3mm
17.08.01.01000.02000.0045	Security Panel	1000	2000	45	30x30-3mm
17.08.01.01250.02000.0045	Security Panel	1250	2000	45	30x30-3mm



Using Area

Safety panels used to ensure the environmental and personnel safety of applications; Factory production lines, machines, transfer units etc. applications can be produced according to the desired size.



**Using Area**

Can be used in production areas, workshops, factories, is suitable for kanban system. They minimize the loss of time between warehouse and assembly by keeping the material ready in production lines and preventing work disruption.



Using Area

Transport carts used for material storage and shipment in production lines can be produced in desired sizes according to the place of use.

Eco Series Study Desk

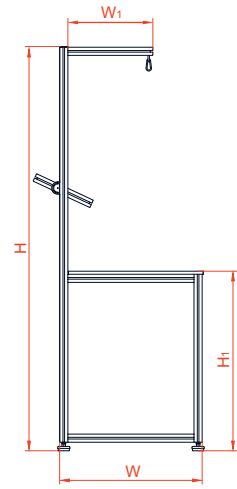
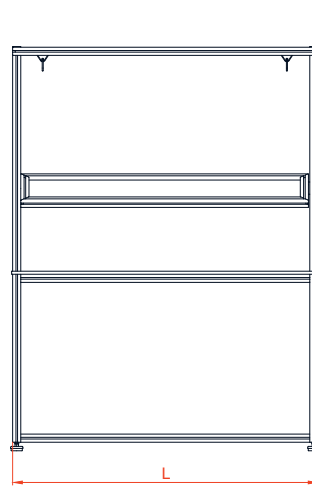
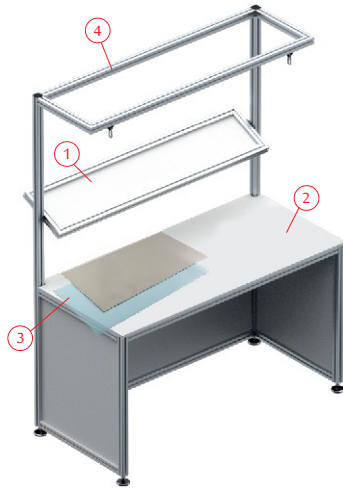

- 1- Tool Rack Hanging Panel
- 2- MDF Table Surface

- 3- Optional Anti Static Table Cloth
- 4- Lightweight Aluminum construction

Code	Name of the product	L	H	H <sub>1</sub>	W	W <sub>1</sub>	Taşıma Kapasitesi
17.07.01.01000.02000.0850	Eco 1000 Study Desk	1000	2000	850	700	350	175 kg
17.07.01.01500.02000.0850	Eco 1500 Study Desk	1500	2000	850	700	350	145 kg
17.07.01.02000.02000.0850	Eco 2000 Study Desk	2000	2000	850	700	350	115 kg

Pro Series Desk

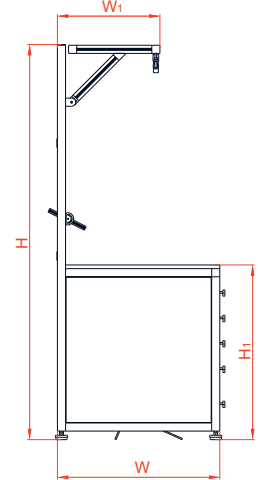
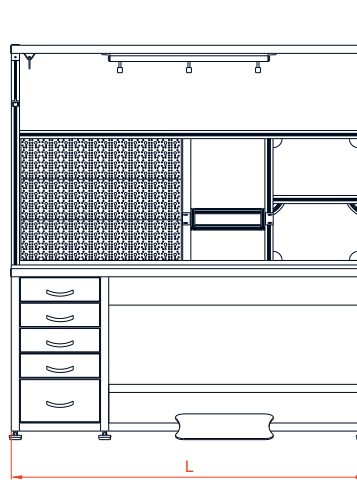
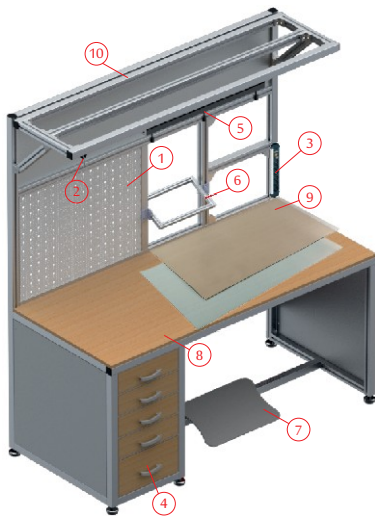

- 1- Tool Rack Hanging Panel
- 2- Sliding Hanger Apparatus
- 3- Four Group Socket
- 4- Functional Drawer

- 5- Adjustable Lighting
- 6- Instruction Panel

- 7- Foot Support
- 8- MDF Table Surface

- 9- Optional Anti Static Tablecloth
- 10- Lightweight Aluminum construction

Code	Name of the product	L	H	H <sub>1</sub>	W	W <sub>1</sub>	Taşıma Kapasitesi
17.07.02.01500.02000.0850	Pro 1500 Desk	1500	2000	850	700	350	205 kg
17.07.02.01750.02000.0850	Pro 1750 Desk	1750	2000	850	700	350	175 kg
17.07.02.02000.02000.0850	Pro 2000 Desk	2000	2000	850	700	350	145 kg

Using Area

product; Test, quality control, production, repair work areas where frequently needed industrial work tables, optional functions can be produced as integrated, designed according to the desired qualities and sizes .

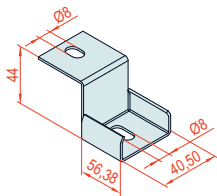
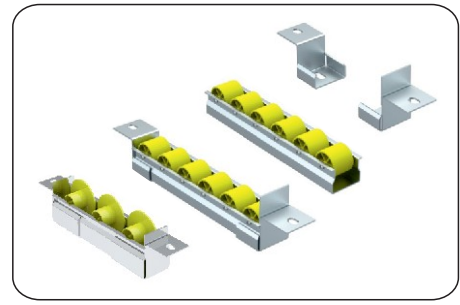
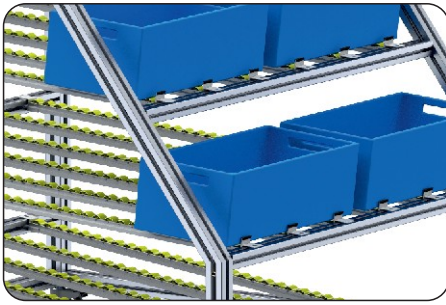

Code: 2.2.017.001.037.01

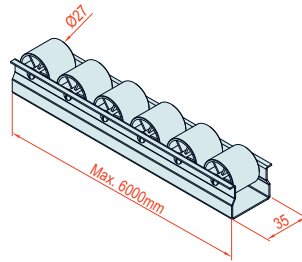

Code: 2.2.016.027.037.01

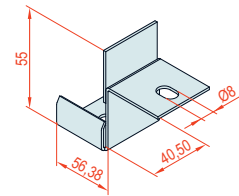

Code: 2.2.017.030.039.01

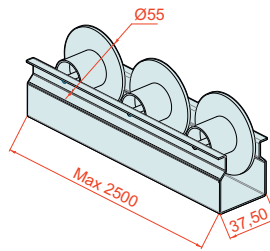

Code: 2.2.016.027.037.03

Code	Name Of The Product	Body	Pulley	Weight
2.2.016.027.037.01	Rail with Pulley 37 mm - Ø27	DKP	Plastic	959 Gr/Mt.
2.2.016.027.037.03	Pulley Rail with Side Support 37 mm - Ø27	DKP	Plastic	1000 Gr/Mt.
2.2.017.001.037.01	Rail Ties with Pulley Small 37 mm	DKP	Plastic	90 Gr
2.2.017.030.039.01	Ray Bag of Pulley. Sheet with Stopper 39x29x89 mm	DKP	Plastic	100 Gr

Using Area

Roller rails allows to the products to slide freely on profiles. Could be various sizes and acts as a guide to orientation purposes.

# OUR NEW SERIES PROFILES

## DESIGN FEATURES

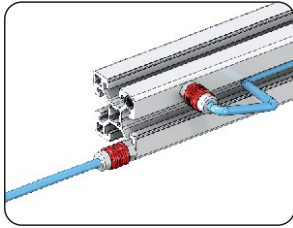

Single Slot Profiles  
Oil and Air Slot Feature

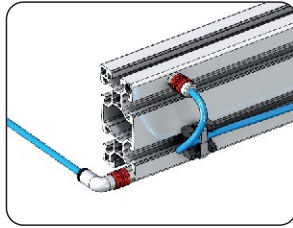

In Dual Slot Profiles  
Oil and Air Slot Feature

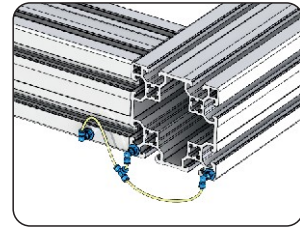

In Multi-Slot Profiles  
With Record Help  
Oil and Air Transfer Feature

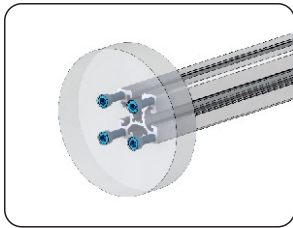

Single Slot Profiles  
Threading on External Slots and  
All Kinds of Part Connection Features

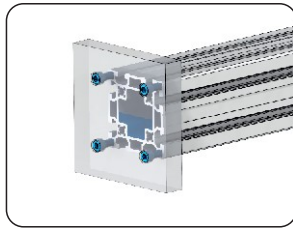

In Multi-Slot Profiles  
Threading on External Slots and  
All Kinds of Part Connection Features

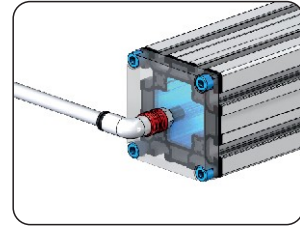

Gasket in Multi-Slot Profiles  
It will provide sealing with  
Liquid Tunneling Feature

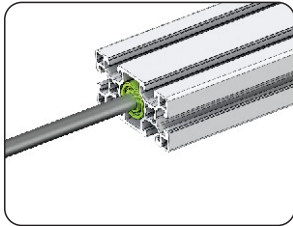

In Dual Slot Profiles  
Shaft Bearing Feature with Bearing

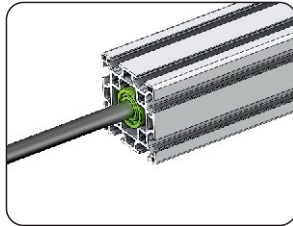

In Dual Slot Profiles  
Shaft Bearing Feature with Bearing

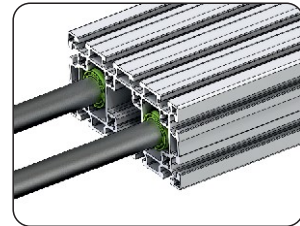

In Multi-Slot Profiles  
Double Body Bearing Feature with Double Bearings

To Examine Our Other Catalogs  
Visit Our Website.



# WORLD WIDE DOĞUŞ KALIP



## Distributors

### LITHUANIA

Uab Elega  
+370 5 2715444  
+370 5 2715445  
lithuania@doguskalip.com.tr  
www.elega.lt

### BULGARIA

TechnoKom Co Ltd.  
+359 32 965 088  
+359 32 965 099  
bulgaria@doguskalip.com.tr  
www.technokom.bg

## Dealers in Turkey

### ANKARA

Sankaya Makina Otomasyon  
(0312) 394 42 07  
(0312) 394 42 07  
ankara@doguskalip.com.tr

### KAYSERİ

Sancak Teknik Paslanmaz  
(0352) 311 51 70  
(0352) 311 51 80  
satis@sancakpaslanmaz.com.tr

### GERMANY

Löwen-Mechanik GMBH  
+49 30 55126014  
+49 178 1632901  
germany@doguskalip.com.tr  
www.loewen-mechanik.de

### CZECH REPUBLIC

Logiman S.R.O  
+00420 603 230 059  
+00420 603 230 059  
czechrepublic@doguskalip.com.tr  
www.logiman.cz

### ÇERKEZKÖY

Trakya Endüstri  
(0282) 726 90 45  
(0282) 726 24 02  
tekirdag@doguskalip.com.tr

### MERSİN

Mutlu Han Proje Danış. Bil. Müh.  
(0324) 359 22 32  
(0324) 359 22 32  
mersin@doguskalip.com.tr

### RUSSIA

ALTERVIA SAINT PETERSBURG  
+7 812 613 63 12  
russia@doguskalip.com.tr  
www.alterv.ru

### GREECE

Meimaridis Bros O.E.  
+30 23310 23342  
+30 23310 67869  
greece@doguskalip.com.tr  
www.aluminium-profile.gr

### ESKİŞEHİR

Linmak Mekatronik San. Tic. Ltd. Şti.  
(0222) 236 26 36  
(0222) 236 26 36  
eskisehir1@doguskalip.com.tr

### RİZE

Pozitif Endüstriyel Ürünleri  
(0464) 217 27 14  
(0464) 217 27 14  
rize@doguskalip.com.tr

### TUNISIA

ALUTEK  
+ 216 71 381 457  
tunisia@doguskalip.com.tr

### ROMANIA

Hsed Hardware & Software Electric Design  
+40 735 523 381  
romania@doguskalip.com.tr  
www.hsed.ro

### KONYA

Pinyon Makine Ekipmanları  
(0332) 502 02 35  
(0332) 502 02 36  
konya@doguskalip.com.tr

### GAZİANTEP

Marmara Teknik Hidrolik Pnömatik Makine  
(0342) 231 58 58  
(0342) 231 58 57  
gaziantep@doguskalip.com.tr





### Doğuş Kalıp sp. zo.o .

Poznan / POLAND

E-Mail: europe@doguskalip.com.tr

#### FACTORY

Mahmutbey Mah. Karaođlanođlu Cad.

No:15/17 Bađcılar / İSTANBUL

Tel: +90 212 480 08 28 Pbx Fax: +90 212 480 08 33

E-Mail: info@doguskalip.com.tr

#### Gebze Branch

Gaziler Mahallesi İbrahim Ađa Caddesi No:273/1

Gebze / KOCAELİ

Tel: +90 262 643 60 40 Fax: +90 262 643 60 50

E-Mail: gebze@doguskalip.com.tr

#### Hadımköy Branch

Alkop San. Sitesi Akçaburgaz Mah. 1592 Sokak A11

Blok No: 9 - 10 Esenyurt / İSTANBUL

Tel: +90 212 858 11 13 Fax: +90 212 858 11 14

E-Mail: hadimkoy@doguskalip.com.tr

#### BayrampaŐa Branch

Terazidere Mah. Çifttehavuzlar Cad. Melihbey İŐhanı

No: 36 /6 BayrampaŐa / İSTANBUL

Tel: +90 212 480 08 21 Pbx Fax: +90 212 480 08 35

E-Mail: bayrampasa@doguskalip.com.tr

#### İkitelli Branch

İkitelli Org. San. Böl. Eskoop San. Sit. C2 Blok No: 48

BaŐakŐehir / İSTANBUL

Tel: +90 212 549 24 06 Fax: +90 212 549 24 11

E-Mail: ikitelli@doguskalip.com.tr

#### İmes Branch

İmes Sanayi Sitesi C Blok 304 Sokak No: 1

Yukarı Dudullu - Ümraniye / İSTANBUL

Tel: +90 216 540 11 23 Fax: +90 216 540 11 25

E-Mail: imes@doguskalip.com.tr

#### Bursa Branch

Üçevler Mah. 78. Sokak (220) Akva Tic.Mer.C Blok

34 Nolu Bađımsız Apartman No:2/A Nilüfer / BURSA

Tel: +90 224 441 42 16 Pbx Fax: +90 224 441 40 34

E-Mail: bursa@doguskalip.com.tr

#### İzmir Branch

Karacaođlan Mah. 6169 Sokak No: 7-A

İŐikkent Bornova / İZMİR

Tel: +90 232 472 24 61 Pbx Fax: +90 232 472 24 60

E-Mail: izmir@doguskalip.com.tr